

ACR10R Rail-type Multi-function Electrical
Instrument with External Split Core Current
Transformer

Use and Installation Manual V1.2

Acrel Co., Ltd.

Announcement

Please read the manual carefully before using the product. The pictures, marks and symbol in the manual belong to Acrel. The manual or part of it shall not be publicly reprinted by people outside the company without written authorization.

The manual will be continuously updated and corrected but it is inevitable to see a little discrepancy or error if compared with the real products. Please refer to the purchased real product.

Content

1. Overview	1
2. Product specification	1
3. Product Function	1
4. Technical Parameters	2
5. Installation	3
5.1 Overall and Installation Dimensions (Unit: mm)	3
5.2 Open Current Transformer's Dimension (Unit: mm)	4
5.3 Installation Method	4
5.4 Connection Mode	4
6. Programming and Use	5
6.1 Button Function Description	5
6.2 Instrument interface display	6
7. Communication wiring	13
7.1 Transmission method	14
7.2 Information frame format	14
7.3 Function Code Introduction	15
7.4 Communication application details	15
7.5 Correspondence between communication value and actual value	29
8 DL/T-645Communication Guide	31
8.1 DL/T645-1997 Protocol Overview	32
8.2 Transmission mode	32
8.3 Protocol	32

Note: The instrument must be installed on the spot together with a complementary split-core current transformer .

1. Overview

The rail-type multifunction electrical instrument with external Rogowski coil and split-core current transformer is applicable for the energy-saving reconstruction project in high energy consumption industries including the smelting, iron and steel, welding and semi-conductor industry. It is also suitable for applications such as the power monitoring of grid-connected cabinet for distributed photovoltaic power cabinet and energy demand management. It boasts of no need of bus removal, easy connection and safe construction, saving reconstruction cost and raising efficiency for the user. It integrates the measurements of all electric parameters (including single-phase or three-phase current, voltage, active power, reactive power, apparent power, frequency and power factor) and comprehensive energy monitoring and examination management. Meanwhile, it also has various peripheral interfaces for the user to choose: the RS485 communication interface with MODBUS-RTU protocol can meet the need of online communication management; the interfaces with switch input and relay output can realize the remote signalling and remote control of the circuit breaker switch. It is very suitable for real-time power monitoring system with an LCD display and the panel buttons to realize the setting and control of parameters.

2. Product specification

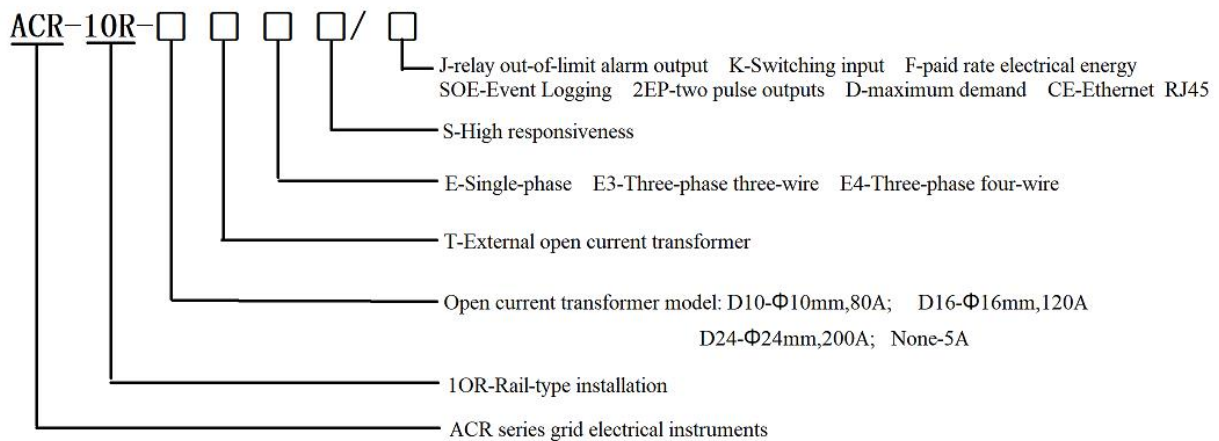

Note: "e" single-phase meter has no "EP" and other optional functions, and EP and j cannot be selected together.

3. Product Function

Model / Function		ACR10R-(DxxT)E4S	ACR10R-(DxxT)ES
		ACR10R-(DxxT)E3S	
Display method	LCD (field LCD)	■	■
Measurement parameters	Current/voltage/frequency/power factor	■	■
	Active/reactive power/apparent power	■	■

	Four-quadrant power measurement	■	■
	Maximum demand	■	■
	Complex rate power metering	■	■
Data logging	Event logging	□	
	Alarm	□	
	Built-in clock	■	■
Communication	RS485 interface	■	■
	Ethernet interface	□	
	RJ45 interface	□	
Optional function (choose one)	Relay output (2DO)	A1+ (B1 or C1) (4DI+2DO or 4DI+EP)*	
Communication	Switching input (4DI)	■	
Optional function (choose one)	Pulse output (2 channels)	A1+ (B1 or C1) (4DI+2DO or 4DI+EP)*	

Note:1.“■”refers to standard function, the standard configuration for above instruments is 1 channel RS485 communication.

- 2、 A1/B1/C1 etc. in the optional function corresponds to the terminal wiring method of 5.4.;
- 3、 Pulse output and relay output are not optional at the same time;
- 4、 When the optional event logging function is equipped, the DI or DO function must be configured.

4. Technical Parameters

Technical parameters		Indicators	
Input	Grid	Three-phase three-wire/three-phase four-wire	
	Frequency	45~65Hz	
	Voltage	Rated voltage:AC 57.7V/100V(100V)、 220V/380V(400V)	
		Overload: 1.2 times the rated voltage(continuous); 2 times the rated voltage lasting for 1 second	
		Power consumption: less than 0.2VA	
	Current	Rating: with external transformer 80A/26.7mA, 120A/40mA, 200A/66.66mA With built-in mutual sensor: 5A	
Overload: 1.2 times the rated current(continuous);10 times the rated current lasting for 1 second			

			Power consumption: less then 0.2VA
Output	Electricity		Output mode:Open collector optocoupler pulse, 2-way output
		Three-phase	Pulse constant:100imp/kWh
	Communication		RS485 interface, Modbus-RTU、 Ethernet
	Display		LCD
Function	On Off	Input	4 dry contact inputs
		Output	Output mode: 2-way relay normally open contact output
	Volume		Contact capacity: AC 250V/3A、 DC 30V/3A
Measurement precision			0.5 level, Reactive energy: 2 level、 Other: 1 level
Power supply			AC85~265V power consumption≤10VA
Safety	Power frequency withstand voltage		AC2kV between power//switching output//current input and voltage input//communication//pulse output//switching input 1min. Power supply//switching output//current input and voltage input between two two AC2kV 1min. AC1kV between communication//pulse output//switching input two by two 1min.
	Insulating resistor		Input and output to chassis >100MΩ
Environment			Working temperature: -10℃~+55℃ (Limit working temperature: -20℃~+65℃) ; Storage temperature: -25℃~+70℃ Relative humidity: 5%~95% non-condensing; altitude: ≤2500m

5. Installation

5.1 Overall and Installation Dimensions (Unit: mm)

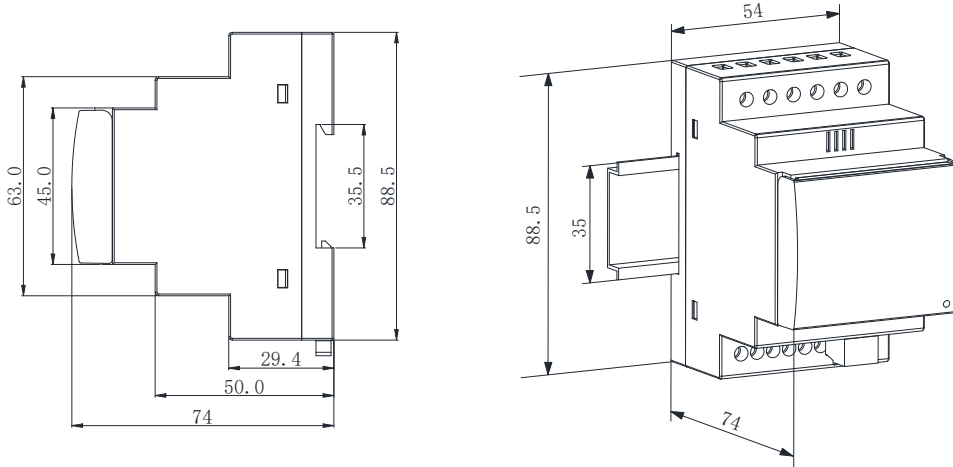

5.2 Open Current Transformer's Dimension (Unit: mm)

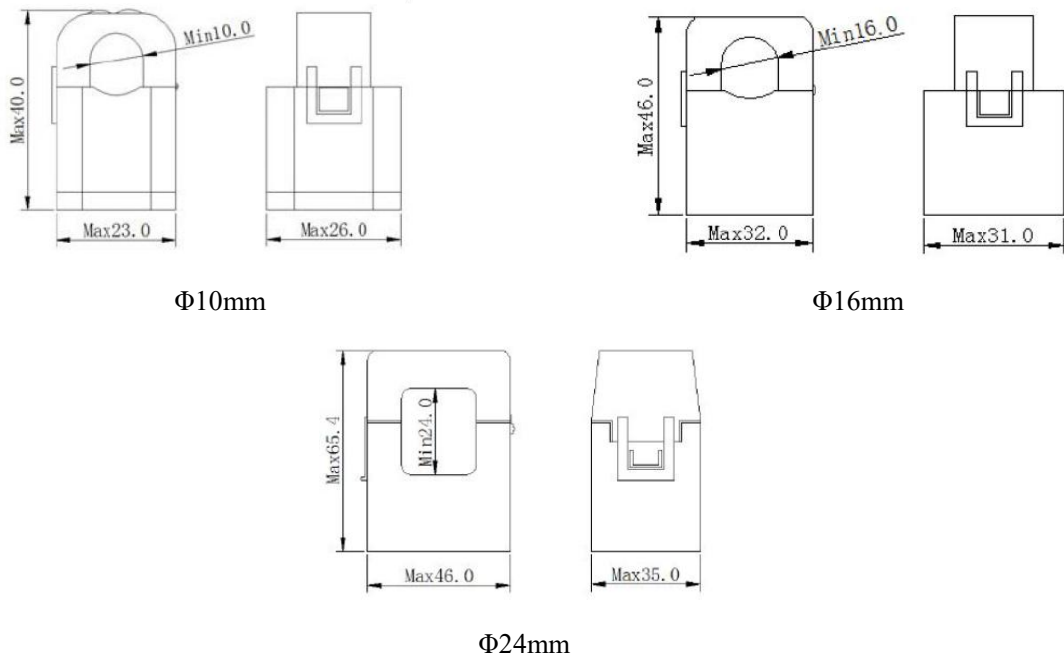

5.3 Installation Method

Instrument mounting method: DIN 35mm standard rail mounting

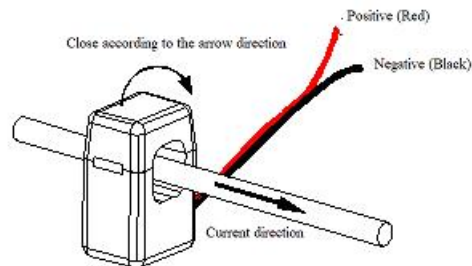

Open-close transformer installation method

5.4 Connection Mode

(Note: The connection diagram on the instrument housing shall prevail in case of any discrepancies with it)

According to different design requirements, it is recommended to add fuses to the power and voltage input terminals to meet the safety requirements of the relevant electrical codes

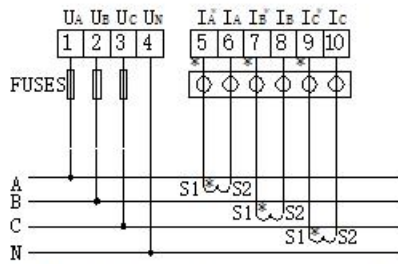

Three phase four wire 3CT

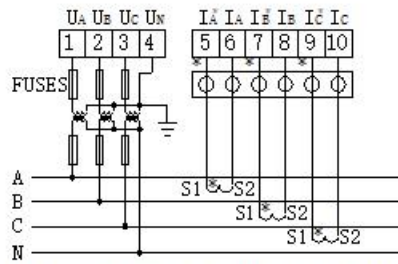

Three phase four wire 3PT 3CT

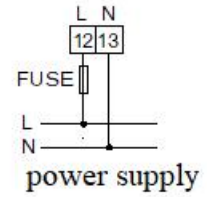

power supply

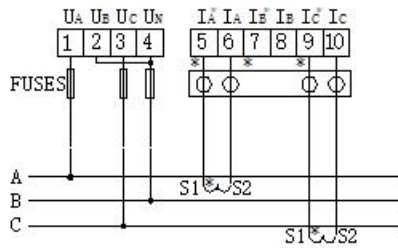

Three phase three wire 2CT

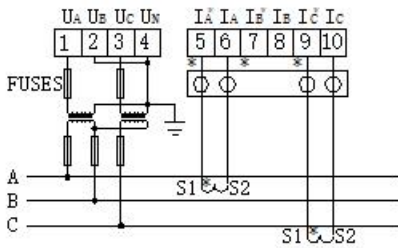

Three phase three wire 2PT 2CT

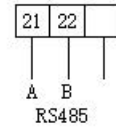

RS485

DI:

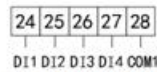

D11 D12 D13 D14 COM1
Switching value input

LAN:



Ethernet communication

DO:



D01 D02
Switching value output

RJ45:



RJ45

Pulse:



EP+ EQ+ E-
Two channel pulse

Note:  is a test terminal for short circuit of CT secondary side:

When three-phase three-wire wiring, terminal 2 and terminal 4 should be connected together externally. The instrument must be installed on site one by one with the matching open and closed transformer, otherwise it will affect the measurement accuracy, and at the same time must ensure a reliable connection between the two.

6. Programming and Use

6.1 Button Function Description

The five buttons of the instrument are FN button, SET button, Enter button from left to right.

FN button	The button function is not yet available.
SET button	In measurement mode, press the key to enter the setting interface In programming mode, it is used to return to the previous level menu

▲ button	In measurement mode, press the key to page up the display item to view the relevant parameters, as described in the display menu. In programming mode, it is used to switch the menu of the same level or the decrease of the digit.
▶ button	In measurement mode, press the key to page down the display item to view the relevant parameters, as described in the display menu. In programming mode, it is used to switch the menu of the same level or the number of digits increase.
Enter button	In the programming mode, it is used to confirm the items selected form the menu and the modification of parameters.

6.2 Instrument interface display

After the instrument is powered on, the interface will be displayed as software version number instantly, and then the screen will be displayed as phase voltage interface immediately, then press SET key to enter the main menu interface. After entering the main menu, you can press the up or down key to select the item you need to view, and press the enter key to enter the item when the item you need to view is in the reverse white state.

6.2.1 Power parameter interface

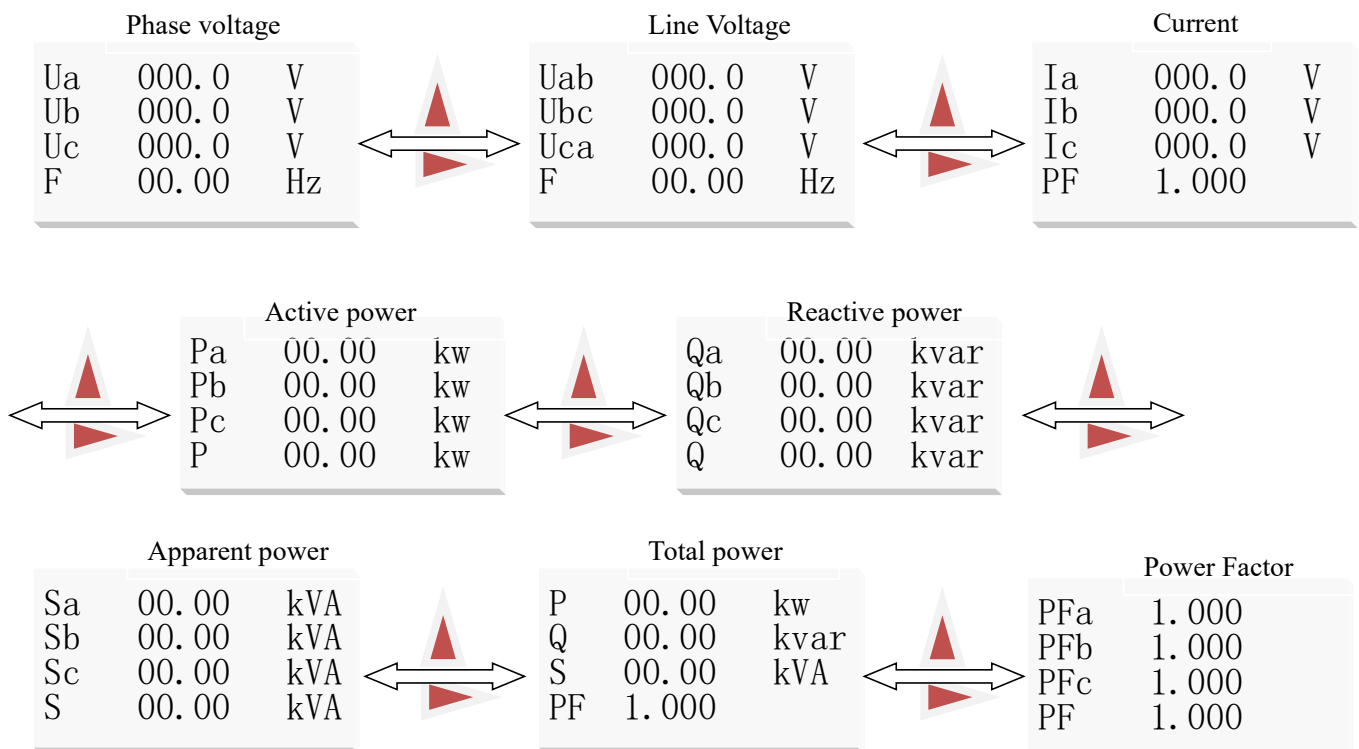



Note: No phase voltage and split-phase power interface when three-phase three-wire

6.2.2 Single-phase interface

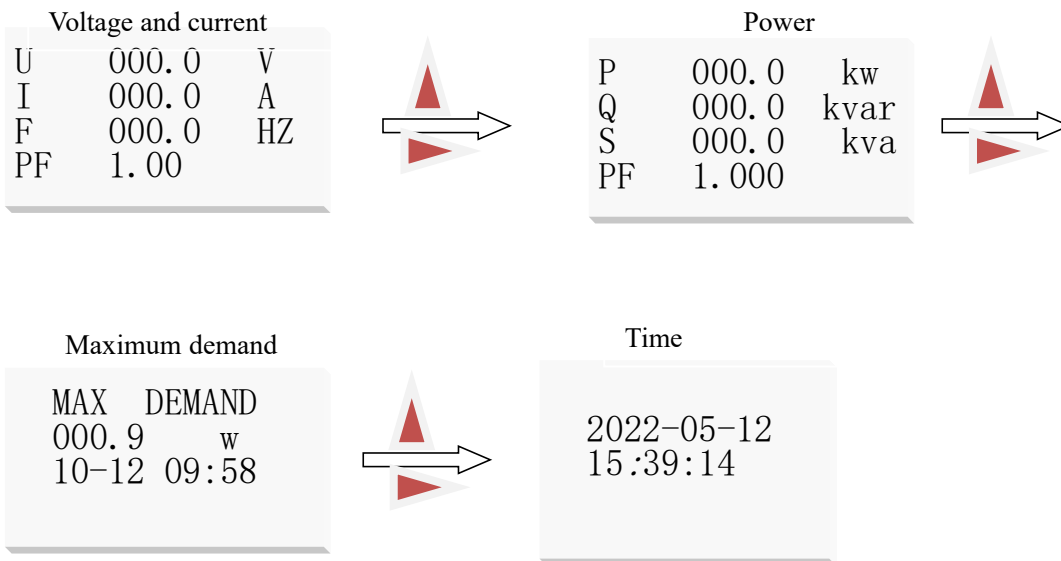

6.2.3 Power display interface

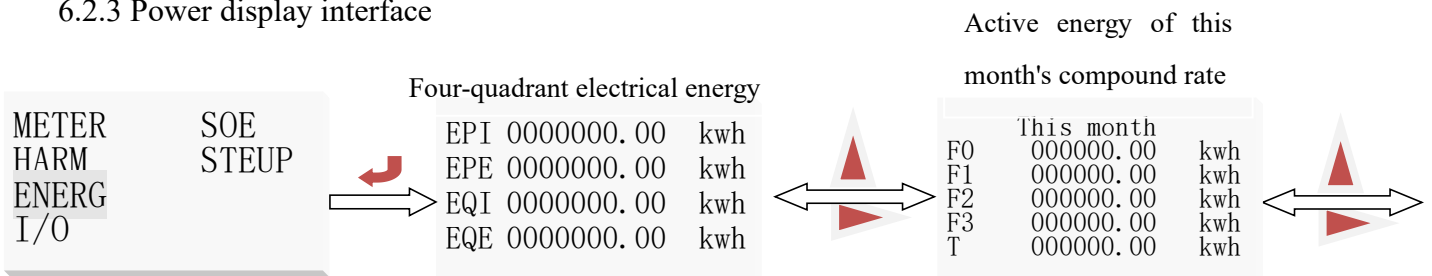

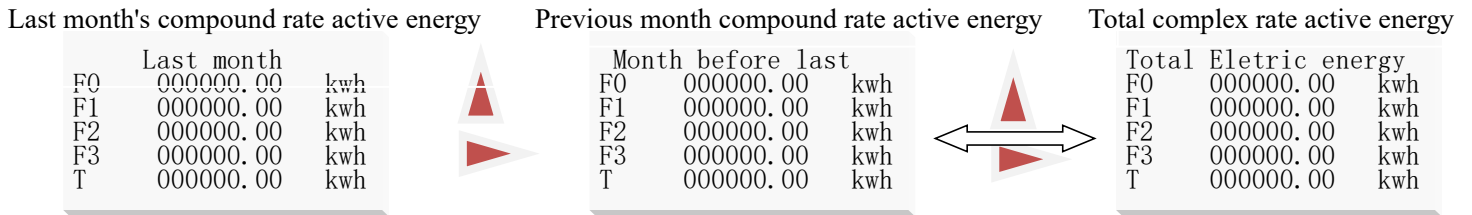

1、 The four quadrants are forward active energy, reverse active energy, inductive reactive energy and capacitive reactive energy, generally speaking, the user reads the forward active energy EPI.

Generally speaking, the user reads the EPI of positive active energy; the energy metering of compound rate is divided into 2 time zones, 8 time zones for one time zone and 9 time zones for two time zones (one time zone can be set by key and communication; two time zones can only be set in the middle, if the factory has been set to dual time zones, adjusting the menu to set the rate can only modify the content of one time zone, to modify to single time zone requires communication setting), 4 kinds of rates (F0 - active peak energy, F1 - active (F0-active peak energy, F1-active peak energy, F2-active flat energy, F3-active valley energy) to complete the time-sharing measurement of energy.

2、 T indicates the total compound rate active energy for the month.

3、 The meter reading day is a natural month, and at the end of each month, 23:59:59 jumps to 00:00:00 on the first day of the following month, the current month's active energy EPI value will be automatically put into the "last month's active energy EPI (F0-T)" display interface, and the last month's active energy EPI (F0-T) value will be put into the "last month's active energy EPI (F0-T)" display interface. The value of last month's active energy EPI (F0-T) is put into the display of "Last month's active energy EPI (F0-T)", and the display of "This month's active energy EIMP (F0-F4)" is cleared to zero.

6.2.4 Switching status display interface

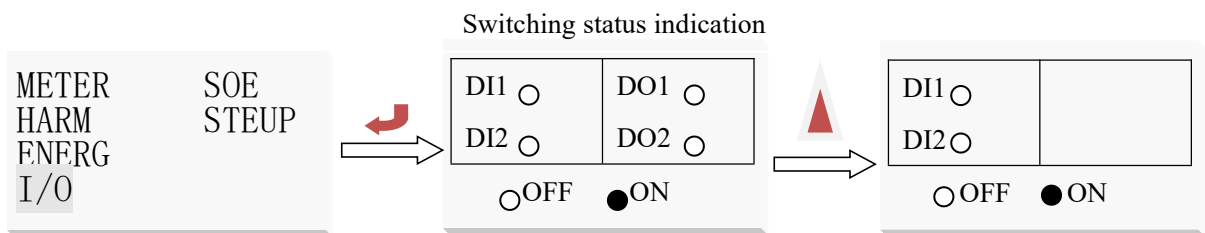

6.2.5 Event Log

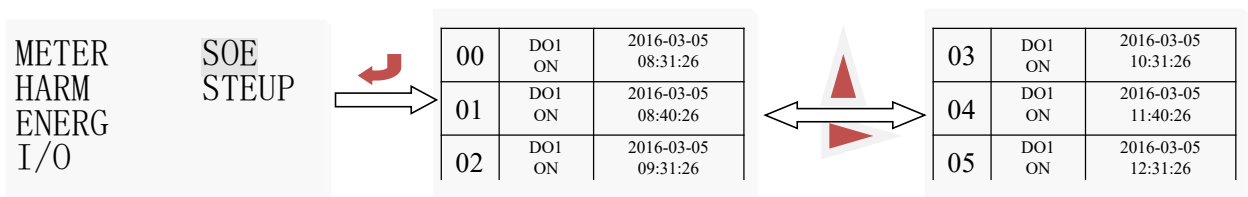

The instrument displays the action information of the switching inputs and outputs by pressing the Enter key

after the event record is selected. As shown above, the 1st record indicates the 1st switch input at 8:31:26 on 5/3/16; the 5th record indicates the 1st switch input at 12:31:26 on 5/3/16. Press the up and down keys to view other records, and a total of 16 records are saved.

6.2.6 Parameter Setting

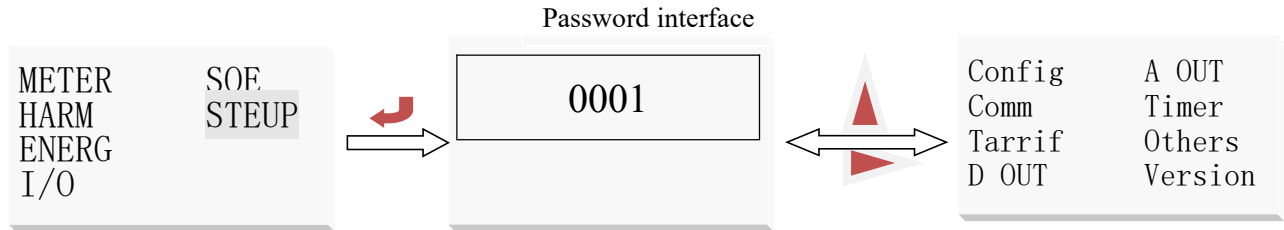

After entering the main menu, press the up or down key to select the user setting item, press the enter key to appear the password input item, then press the up or down key to make the cursor move on the individual, ten, hundred and thousand digits, when the bit is in the anti-white state, you can press the left or right key to increase or decrease the digit of the bit, the password (default is 0001) is entered correctly and press the enter key to enter the user setting interface.

6.2.6.1 Parameter Setting

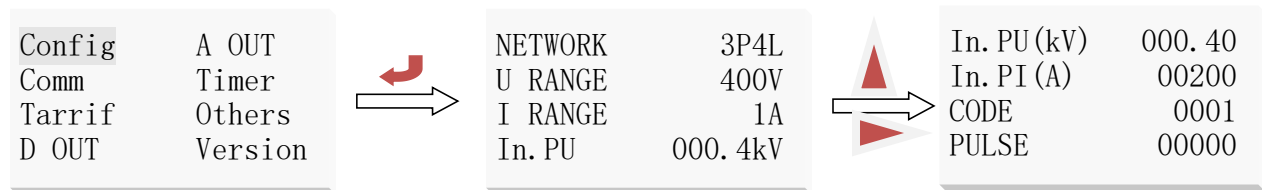

After entering the user setting interface, press the up and down keys to select system setting, and then press the Enter key to enter the system setting interface. Press the up and down keys under the system setting interface to select the item that needs to be changed so that it is in the reverse white state.

	Description	Remark
NETWORK	Wiring mode: three-phase four-wire, three-phase three-wire, single-phase	
U RANGE	Secondary voltage: 100V, 400V	220V/380Vboth choose400V
I RANGE	Internal calibration current factor	Customer is meaningless, no need to set
In.PU	Primary voltage value	Unit: kV
In.PI	Primary current value	Customer can set according to the actual current
CODE	Password setting	Default 0001

Example.

Customer order model is voltage: 10KV/100V, current: 600A/5A, at this time U RANGE should be set to 100V,

In.PU is set to 10kV, PI is set to 600

6.2.6.2 Communication settings

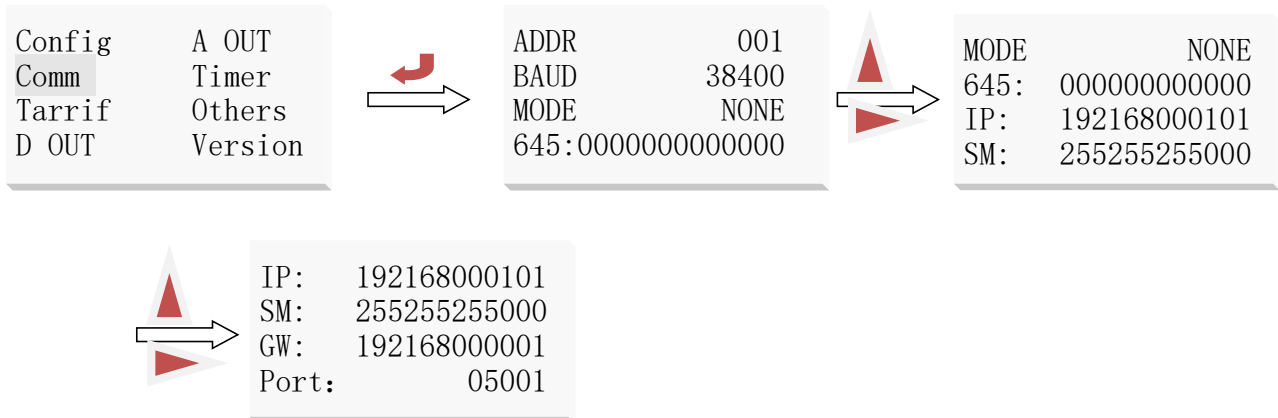

After entering the user setting interface, press the up and down keys to select communication setting and press the Enter key to enter the communication setting interface. In the communication setting interface, press the up and down keys to select the item that needs to be changed to make it in the inverted state. Press the left and right keys to change the communication address (1 to 247), communication baud rate (1200 bps, 2400 bps, 4800 bps, 9600 bps, 19200 bps, 38400 bps), parity mode (no parity, odd parity, even parity, 2bits),645 protocol address,IP address, Subnet mask,gateway,and Ethernet port number.

6.2.6.3 Rate Setting

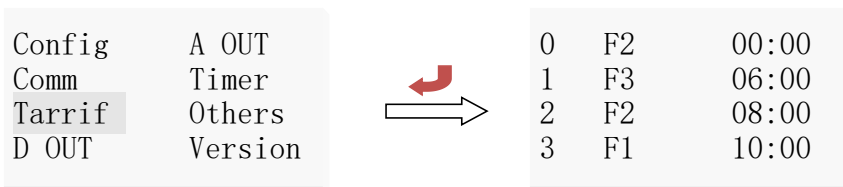

After entering the user setting interface, press the up and down keys to select the rate setting, and press the Enter key to enter the rate setting interface. The meter can set two time zones, 14 time periods and four rates (spike and valley). Under the time zone setting interface, press the up and down keys to select the desired setting item, and press the left and right keys to modify the setting item value. The following table shows.

Note : The time after the rate time must be larger than the one before when setting the rate time, otherwise there will be an error.

Serial number	Time	Description
1	00: 00	00: 00~06: 00 In the time period, the rates are flat
2	06: 00	06: 00~08: 00 In the time period, the rates are valley
3	08: 00	08: 00~10: 00 In the time period, the rates are flat
4	10: 00	10: 00~12: 00 In the time period, the rate is peak
5	12: 00	12: 00~14: 00 In the time period, the rate is peak
6	14: 00	14: 00~16: 00 In the time period, the rates are flat

7	16: 00	16: 00~22: 00 In the time period, the rates are flat
8	22: 00	22: 00~00: 00 In the time period, the rate is pointed

6.2.6.4 Switching settings

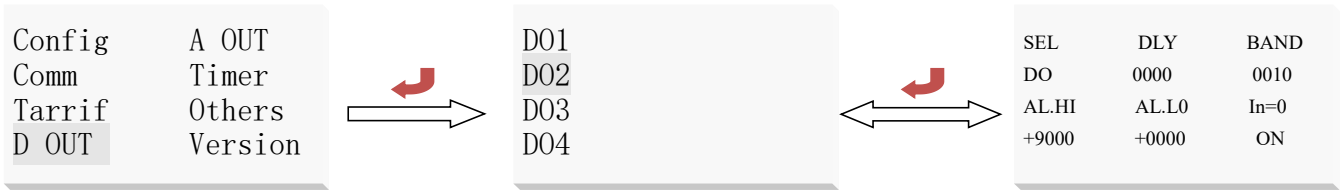

After entering the user setting interface, press the up and down key to select the switch (DO1~DO4) setting, and press the enter key to enter the switch setting interface.

The DO output type is set in "SEL", "0. do" means for communication control (at this time, if DLY is set to 0, the output is level mode, otherwise it is pulse mode, if DLY is set to 2, it will be automatically disconnected after 0.02 seconds of suction), other for the alarm control (see the following table)

"dLy" for the alarm delay (alarm time is recommended not to set to 0 to prevent interference false movement.)

"bAnd" for the non-action belt setting

"Hi" for the high alarm value setting (do not need to set the maximum 9999)

"Lo" for the low alarm value settings (do not set the minimum -9999)

(The above 3 settings correspond to the display value of power, and the display contains a decimal point. Example: input 220V 100A/5A, three-phase four-wire, then 100% P total $220 * 100 * 3 = 66kW$. such as 100% power when high alarm, "AL.Hi" can be 66.00; 100% voltage when high alarm, "AL. Hi" can be taken as 220.0; "AL.Hi" can be taken as 100.0 for high alarm at 100% current)

"In.=0" is whether to allow low alarm when the signal is 0, Lo.on enable, Lo.of disable.

		First relay output							
SEL	0	The DO output mode is controlled by communication, where "dLy" is 0 for level control.							
	do	The delay time "dLy" (in 0.0 sec.) after DO action is set to auto return mode. (in 0.0 second) and then disconnect automatically.							
	01	02	03	04	05	06	07	08	
	U _A	U _B	U _C	Phase voltage alarm value	U _{AB}	U _{BC}	U _{CA}	Line voltage alarm value	
	09	10	11	12	13	14	15	16	
	I _A	I _B	I _C	Current alarm value	PA	PB	PC	Total P	
	17	18	19	20	21	22	23	24	
	Q _A	Q _B	Q _C	Total Q	SA	SB	SC	Total S	
	25	26	27	28	29	30	31	32	
	PFA	PF _B	PF _C	PF	F	Voltage imbalance	Current imbalance	Neutral line current	
DLY	Output delay time								

	If it is DO output mode, when set to 0, it is level control mode, and when it is not 0, it is pulse control mode, and it will be disconnected after the time delay set, unit: 1 second.
BAND	No action band interval
AL.Hi	High alarm value Range -9999 to 9999 (ignore decimal point position)
AL.Lo	Low alarm value Range -9999 to 9999 (ignore decimal point position)
Lo.on	Low alarm can be triggered when the Lo.on signal is 0 Low alarm is not triggered when Lo.oF signal is 0

Note: 1. The most value of three-phase XX means: the maximum value in three phases when high alarm is set, and the minimum value in three phases when low alarm is set.

2. The 2nd DO can set "32.FL" combined alarm function, after setting the secondary menu becomes "SEL" (function selection), "dLy" (time delay), "H-U" (over line voltage), "L-U" (over line voltage), and "L-U" (over line voltage). "H- U" (over line voltage), "L- U" (under line voltage), "H- F" (over frequency), "L- F "(under frequency), "H- P" (over power), "L- P" (under power), "H- I" (over current), and "L-PF" (under power factor), "H-b.U" (overvoltage unbalance, set to -1 phase break, judgment condition at least one phase > 0.5Ue, at least one phase < 0.1Ue), "H-b. I" (overcurrent unbalance, set to -1 phase break, judgment condition is at least one phase > 0.2Ie, at least one phase < 0.01Ie)

3. Unbalance calculation

(the difference between the largest value of offset average and the average value)/average value*100%, if the average value of the denominator is less than the rated value, the denominator is the rated value.

Voltage rating Ue: 3-phase 4-wire Ue is phase voltage, the meter set in the menu is 220V*PT for 400V, and 57V*PT for 100V.

Current rating Ie: 5A*CT for a 5A meter and 1A*CT for a 1A meter.

The parameters set under unbalance are in percentage format, such as set to 20 to indicate 20%.

6.2.6.5 Variable transmission setting (function not available yet)

Config	A OUT
Comm	Timer
Tarrif	Others
D OUT	Version

6.2.6.6 Time Settings

Config	A OUT		2022-05-18
Comm	Timer		12: 34: 15
Tarrif	Others		BlacLight ON
D OUT	Version		

After entering the user settings screen, press the up and down keys to select the time setting, and then press the Enter key to enter the time setting interface. After entering the time setting interface, press the up and down keys to

select the item you want to set, and press the left and right keys to modify the value of the setting item.

Note: Illegal time cannot be saved (e.g. 25:05 on May 18, 2022 cannot be entered if it is illegal)

6.2.6.7 Other settings

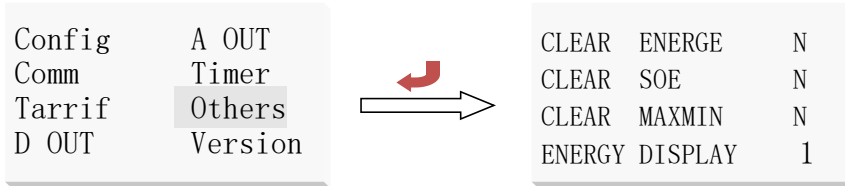

After entering the user setting interface, press the up and down keys to select other settings, and then press the Enter key to enter the parameter clear interface. Press the up and down keys to select the desired setting item, and press the left and right keys to clear the setting item value. The interface of electricity clearing includes CLEAR ENERGE, CLEAR SOE, CLEAR MAXMIN and ENERGY DISPLAY.

Note: If you want to clear the electricity, select "Yes", and then press the Enter key, the electricity will be cleared and cannot be restored, and the data of the maximum demand will also be cleared.

Version information: The version information is displayed on the power on, users can also view the relevant version information of the meter in this interface.

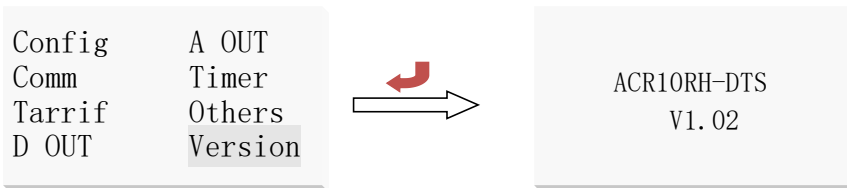

7. Communication wiring

The instrument provides an asynchronous half-duplex RS485 communication interface using the MODBUS-RTU protocol, which allows various data messages to be transmitted on the communication line. Theoretically, up to 128 instruments can be connected simultaneously on one line, and each instrument can set its communication address (Addr), and the communication rate (baud) can be selected by setting.

It is recommended to use two shielded wires, A and B, with the shield connected to earth, and to keep the communication lines away from strong cables or other strong electric fields.

It is recommended to add matching resistors between A and B of the most terminal instrument, with resistance values ranging from 120Ω to 10kΩ.

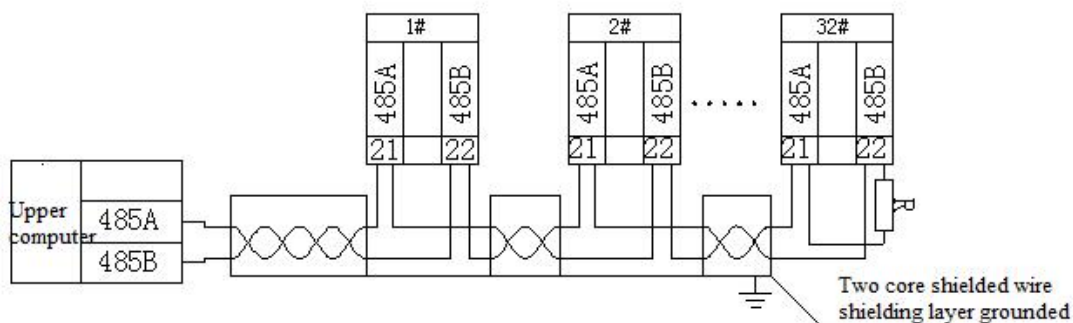

7.1 Transmission method

The information is transmitted asynchronously and in bytes. The communication information passed between the host and the slave is in 10-bit word format, containing 1 start bit, 8 data bits (the least significant bit is sent first), no parity bit, and 1 stop bit, or 11-bit word format if set to and parity bit or 2 stop bits.

7.2 Information frame format

Address code	Function code	Data area	CRC validation code
1 Byte	1 Byte	N Bytes	2 Bytes

Address code: The address code is at the beginning of the frame and consists of one byte (8-bit binary code), decimal 0 to 255, in the PZ meter only 1 to 247 are used, the other addresses are reserved. These bits mark the address of the user-specified terminal device that will receive data from the host to which it is connected. The address of each terminal device must be unique, and only the addressed terminal will respond to a query containing that address. When a terminal sends back a response, the slave address data in the response tells the host which terminal is communicating with it.

Function Code: The function code tells the addressed terminal what function to perform. The following table lists the function codes used by this family of instruments, along with their meaning and function.

Function	Definition	Operation
03H/04H	Read data register	Get the current binary value of one or more registers
10H	Preset multiple registers	Set binary value to a series of multiple registers

Data area: The data area contains the data required by the terminal to perform a specific function or the data collected by the terminal in response to a query. The content of this data may be numeric values, reference addresses, or set values. For example, while the function code tells the terminal to read a register, the data area needs to indicate which register to start from and how many data to read, with the embedded address and data varying according to the type and content between slaves.

CRC validation code: the error check (CRC) field occupies two bytes and contains a 16-bit binary value. the CRC value is calculated by the transmitting device and appended to the data frame. the receiving device recalculates the CRC value when receiving the data and compares it with the value in the received CRC field. if the two values are not equal, an error has occurred.

The flow of generating a CRC is as follows

- a. Preset a 16-bit register as 0FFFFH (all 1s), called CRC register.
- b. Operate the first byte of the data frame with the low byte of CRC register and store the result back to CRC register.
- c. Shift the CRC register to the right by one bit, fill the highest bit with 0, and shift the lowest bit out and detect.
- d. If the lowest bit is 0, repeat the third step (next shift); if the lowest bit is 1, the CRC register is iso-or-operated with a preset fixed value (0A001H).

- e. Repeat the third and fourth steps until 8 shifts. This finishes processing a complete eight bits.
- f. Repeat step 2 to step 5 to process the next octet until all bytes are processed.
- g. The final CRC register value is the CRC value.

There is also a method to calculate CRC using a pre-defined table, its main feature is fast calculation, but the table requires more storage space, the method is not repeated here, please refer to the relevant information

7.3 Function Code Introduction

7.3.1 Function code 03H: Read register

This function allows the user to obtain the data collected and recorded by the device and the system parameters. There is no limit to the number of data that can be requested by the host at one time, but it cannot exceed the defined address range.

The following example reads 3 basic data (2 bytes per address in the data frame) UAB, UBC, UCA from slave 01, where UAB has address 246(F6H), UBC has address 247(F7H), and UCA has address 248(F8H).

Host		Send message	Slave return		Return information
Address code		01H	Address code		01H
Function code		03H	Function code		03H
Start address	High byte	00H	Number of bytes		06H
	Low byte	F6H	Register data	High byte	Indefinite value
Number of registers	High byte	00H		Low byte	Indefinite value
	Low byte	03H	Register data	High byte	Indefinite value
CRC check code	Low byte	E5H		Low byte	Indefinite value
	High byte	F9H	Register data	High byte	Indefinite value
		Low byte		Indefinite value	
			CRC check code	Low byte	Indefinite value
				High byte	Indefinite value

7.4 Communication application details

The instrument is designed with a unified plan for the communication address table, and users can easily realize telemetry, telematics and remote control functions according to the following introduction.

7.4.1 Communication Description

ACR series rail meter communication adopts MODBUS-RTU communication protocol, MODBUS protocol defines in detail the check code, data sequence, etc., which are necessary for specific data exchange.

Address	Name	Type	Remarks	word
0	Instrument address	R/W	Address of the instrument in the network node (001---127)	1

1	Communication rate	R/W	0--4800bps 3--38400bps(default communication rate) 1--9600bps 4--2400bps 2--19200bps 5--1200bps	1
2	Communication parity mode	R/W	0--No parity bit (default mode) 2--Even parity bit 1--Odd parity bit 3--2 bits	1
3	Wiring method	R/W	0--3-phase 3-wire 1--3-phase 4-wire	1
4	Secondary side rated voltage value Ue	R/W	0--100V 2--660V 1--400V	1
5	Secondary side rated voltage value Ie	R/W	0--1A	1
6	Primary side rated voltage value PU	R/W	1~65000,2 decimal places, corresponding to 0.01-650.00kV	1
7	Primary side rated voltage value PI	R/W	1~65000A	1
8	Backlight delay time	R/W	When set to 0, the backlight is always on. When set to 1-255, the backlight goes off after 1-255 seconds.	1
9	Switching delay time	R/W	When set to 0, relay 1 is level-controlled. When set to 1-255, relay 1 is pulse control mode, unit 0.01 second.	1
10	Switching delay time	R/W	When set to 0, relay 2 is level-controlled. When set to 1-255, relay 2 is pulse control mode, unit 0.01 second.	1
11	Switching delay time	R/W	When set to 0, relay 3 is level-controlled. When set to 1-255, relay 3 is pulse control mode, unit 0.01 second.	1
12	Switching delay time	R/W	When set to 0, relay 4 is level-controlled. When set to 1-255, relay 4 is pulse control mode, unit 0.01 second.	1
14-15	Voltage primary and secondary side coefficients	R	Float	2
16-17	Current primary and secondary coefficients	R	Float	2
18-19	Power and energy primary	R	Float	2

	and secondary side coefficients			
21-23	Compound Rate Period 1	R/W	The complex rate information is divided into 8 time periods and four rates; each time period occupies three words: the first word is the hour, the second word is the minute, and the third word is the rate type; the four rates are: 0 - sharp 1 - peak, 2 - flat, 3 - valley.	3
24-26	Compound Rate Period 2	R/W		3
27-29	Compound Rate Period 3	R/W		3
30-32	Compound Rate Period 4	R/W		3
33-35	Compound Rate Period 5	R/W		3
36-38	Compound Rate Period 6	R/W		3
39-41	Compound Rate Period 7	R/W		3
42-44	Compound Rate Period 8	R/W		3
53	The first switch input	RO	1 with open input, 0 without open input.	1
54	Second switch input	RO		1
55	The third switch input	RO		1
56	The fourth switch input	RO		1
57	The fifth switch input	RO		1
58	Sixth switch input	RO		1
59	Seventh switch input	RO		1
60	Eighth switch input	RO		1
61	The first switch output	R/W	When 1 is written, the output relay contact is closed. When 0 is written, the output relay contacts are separated.	1
62	The second switch output	R/W	When 1 is written, the output relay contact is closed. When 0 is written, the output relay contacts are separated.	1
63	The third switch output	R/W	When 1 is written, the output relay contact is closed. When 0 is written, the output relay contacts are separated.	1
64	The fourth switch output	R/W	When 1 is written, the output relay contact is closed. When 0 is written, the output relay contacts are separated.	1
128	Year	R/W	Time; // BCD code format.	1
129	January	R/W	To set the time you need to use the 10H command to set all the times	1
130	Day	R/W		1
131	hour	R/W		1

132	minutes	R/W		1
133	seconds	R/W		1
143-148	Event Log 1	RO	Reserved	6
149-154	Event record 2	RO	Reserved	6
155-160	Event record 3	RO	Reserved	6
161-166	Event log 4	RO	Reserved	6
167-172	Event record 5	RO	Reserved	6
173-178	Event Log 6	RO	Reserved	6
179-184	Event log 7	RO	Reserved	6
185-190	Event log 8	RO	Reserved	6
191-196	Event log 9	RO	Reserved	6
197-202	Event Log 10	RO	Reserved	6
203-208	Event Log 11	RO	Reserved	6
209-214	Event Record 12	RO	Reserved	6
215-220	Event Record 13	RO	Reserved	6
221-226	Event Record 14	RO	Reserved	6
227-232	Event Record 15	RO	Reserved	6
233-238	Event Record 16	RO	Reserved	6
242	Neutral line current	RO	Secondary side Current fractional digits: 3	1
243	Phase voltage Uan	RO	Secondary side Voltage decimal places: 1	1
244	Phase voltage Ubn	RO	Secondary side	1
245	Phase voltage Ucn	RO	Secondary side	1
246	Line voltage Uab	RO	Secondary side	1
247	Line voltage Ubc	RO	Secondary side	1
248	Line voltage Uca	RO	Secondary side	1
249	Phase current Ia	RO	Secondary side Number of decimal places of current: 3	1
250	Phase current Ib	RO	Secondary side	1
251	Phase current Ic	RO	Secondary side	1
252	Frequency F	RO	Number of decimal places of frequency: 2	1
253-254	Phase A active power Pa	RO	Secondary side power, 2 decimal places, in W	2
255-256	Phase B active power Pb	RO	Secondary side power, 2 decimal places, in W	2
257-258	Phase C active power Pc	RO	Secondary side power, 2 decimal places, in W	2
259-260	Total active power P total	RO	Secondary side power, 2 decimal places, in W	2
261-262	Phase A reactive power Qa	RO	Secondary side power, 2 decimal places, in var	2

263-264	Phase B reactive power Qb	RO	Secondary side power, 2 decimal places, in var	2
265-266	Phase C reactive power Qc	RO	Secondary side power, 2 decimal places, in var	2
267-268	Total reactive power Q total	RO	Secondary side power, 2 decimal places, in var	2
269-270	Phase A apparent power Sa	RO	Secondary side power, 2 decimal places, in VA	2
271-272	Phase B apparent power Sb	RO	Secondary side power, 2 decimal places, in VA	2
273-274	Phase C apparent power Sc	RO	Secondary side power, 2 decimal places, in VA	2
275-276	Total apparent power S total	RO	Secondary side power, 2 decimal places, in VA	2
277	A-phase power factor	RO	Power Factor Number of decimal places: 3	1
278	B-phase power factor	RO		1
279	C-phase power factor	RO		1
280	Total power factor	RO		1
287	Phase A current K-factor	RO	K-factor Fractional digit: 2	1
288	Phase B current K factor	RO		1
289	C-phase current K-factor	RO		1
299	Voltage unbalance degree	RO	Voltage imbalance Number of decimal places: 1	1
300	Current unbalance degree	RO	Current unbalance fractional digits: 1	1
301-302	Maximum demand	RO	Maximum demand fractional digits: 2	2
303-306	Maximum demand occurrence time	RO	Time; // BCD code format.	4
333-334	Peak active energy of the month	RO	Secondary power, 2 decimal places, in kWh	2
335-336	Active flat power of the month	RO	Secondary energy, 2 decimal places, in kWh	2
337-338	Active valley power for the month	RO	Secondary power, 2 decimal places, in kWh	2
339-340	Total active energy of the month	RO	Secondary electricity, 2 decimal places, in kWh	2
341-342	Last month's peak active energy	RO	Secondary electricity, 2 decimal places, in kWh	2
343-344	Last month's active flat power	RO	Secondary electricity, 2 decimal places, in kWh	2
345-346	Active valley power of last month	RO	Secondary electricity, 2 decimal places, in kWh	2
347-348	Last month's total active	RO	Secondary electricity, 2 decimal places, in kWh	2

	energy			
349-350	Previous month's peak active energy	RO	Secondary electricity, 2 decimal places, in kWh	2
351-352	Previous month's active flat power	RO	Secondary electricity, 2 decimal places, in kWh	2
353-354	last month's active valley energy	RO	Secondary side power, 2 decimal places, in kWh	2
355-356	Total active energy in the previous month	RO	Secondary side power, 2 decimal places, in kWh	2
357-358	Total peak active energy	RO	Secondary side power, 2 decimal places, in kWh	2
359-360	Total active flat power	RO	Secondary side power, 2 decimal places, in kWh	2
361-362	Total active valley energy	RO	Secondary electricity, 2 decimal places, in kWh	2
363-364	Total reactive rate active energy	RO	Secondary electricity, 2 decimal places, in kWh	2
365-366	Positive active energy EPI	RO	Secondary electricity, 2 decimal places, in kWh	2
367-368	Reverse active energy EPE	RO	Secondary electricity, 2 decimal places, in kWh	2
369-370	Inductive reactive energy EQL	RO	Secondary electricity, 2 decimal places, in kWh	2
371-372	Capacitive reactive energy EQC	RO	Secondary side power, 2 decimal places, in kWh	2
559-590	A-phase voltage sampling point (32 points/wave)	RO	A-phase voltage sampling point	32
591-622	B-phase voltage sampling point (32 points/wave)	RO	B-phase voltage sampling point	32
623-654	C-phase voltage sampling point (32 points/wave)	RO	C-phase voltage sampling point	32
655-686	A-phase current sampling points (32 points/wave)	RO	A-phase current sampling point	32
687-718	B-phase current sampling point (32 points/wave)	RO	B-phase current sampling point	32
719-750	C-phase current sampling point (32 points/wave)	RO	C-phase current sampling point	32
1000	DIDO status	R/W	The high byte is DI (bit0 is DI1, bit1 is DI2, and so on, bit7 is DI8), the low byte is DO (bit0 is DO1, bit1 is DO2, and so on, bit7 is DO8)	1

1001	1st alarm selection	R/W	0-32, see the correspondence in the table of 6.2.6.4 for details If the total active power alarm, this value is 16.	1
1002	1st alarm delay time	R/W	0-9999 Unit: s; If the total active power is alarmed, this value is 16.	1
1003	1st alarm deadband	R/W	-9999 - 9999 See 6.2.6.4 for details, example: the displayed value is 66.00Kw, the communication value is 6600	1
1004	1st alarm high alarm	R/W		1
1005	1st alarm low alarm	R/W		1
1006	1st way alarm 0 alarm	R/W	0 – 1 (0: Enable, 1: Prohibition)	1
1007-1012	2nd way (same as above)	R/W	More than the first road a combination of alarm selection, the type of selection for 0-32 (when the value is 32, corresponding to the setting of the address 1030-1037 effective), the rest of the same as the first road	6
1013-1018	Route 3 (same as above)	R/W	Same as the first road	6
1019-1024	Road 4 (same as above)	R/W	Same as above	6
1030	Over frequency	R/W	Combined alarm parameter, -9999 - 9999 is only valid when the second alarm is a combined alarm, see 6.2.6.4 for details; example: the display value is 66.00Kw, the communication value is 6600	1
1031	Under frequency	R/W		1
1032	Over power	R/W		1
1033	Under power	R/W		1
1034	Over current	R/W		1
1035	Under Power Factor	R/W		1
1036	Over voltage unbalance	R/W	-1 - 9999 See 6.2.6.4 for details, example: the display value is 55.00Kw, the communication value is 5500	
1037	Over current unbalance	R/W		
1038	Combined alarm status	RO	The 0th bit indicates the over-voltage alarm status, the first bit indicates the under-voltage alarm status, and so on to the 9th bit	
1040	1st variable transmission selection (low byte valid)	R/W		1
1041	1st high transmission	R/W		1
1042	1st channel low transmission	R/W		1
1043-1045	2nd variable transmission	R/W		3
1046-1048	3rd variable transmission	R/W		3
1049-1051	4th channel variable	R/W		3

	transmission			
1100-1102	DLT/645 address	R/W		3
1103	Communication rate of the second communication	R/W	0--4800bps; 4--2400bps 1--9600bps; 5--1200bps 2--19200bps; 3--38400bps(Default communication rate)	1
1104	Second communication check mode	R/W	0--No parity bit(Default method); 1 - Odd check digit; 2 - even parity bit. 3--2 bits	1
1200-1211	1 Time zone parameters	R/W	1 time zone is divided into 8 time periods; each time period occupies 1.5 words, the first byte is the hour, the second byte is the minute, the third byte is the rate type, the four rates are 0-tip, 1-peak, 2-even, 3-valley	27
1212-1225	2 Time zone parameters	R/W	1 time zone is divided into 9 time periods; each time period occupies 1.5 words, the first byte is the hour, the second byte is the minute, the third byte is the rate type, the four rates are 0-tip, 1-peak, 2-even, 3-valley	
1225-1226	Time zone type selection	R/W	The low 8 bits of 1225 is the lost selection for January-August, the 8th bit is the time zone selection for January, (0: select time zone 1, 1: select time zone 2), and so on, the 1st bit is the time zone selection for August; the high 4 bits of 1226 is the time zone selection for September-December, the 16th bit is the time zone selection for September, and so on, the 13th bit is the time zone selection for December (0: select time zone 1, 1: select time zone 2)	
1250-1251	Historical January active peak energy	RO	Secondary power measurement, 2 decimal places	2
1252-1253	Historical January active peak energy	RO	Same as above	2
1254-1255	History of active flat energy in January	RO	Same as above	2
1256-1257	History of active valley energy in January	RO	Same as above	2

1258-1259	History of total active energy in January	RO	Same as above	2
1260-1269	History of active energy in February	RO	Same as above	10
1270-1279	History of active energy in March	RO	Same as above	10
1280-1289	History of active energy in April	RO	Same as above	10
1290-1299	History of active energy in May	RO	Same as above	10
1300-1309	History of active energy in June	RO	Same as above	10
1310-1319	History of active energy in July	RO	Same as above	10
1320-1329	History of active energy in August	RO	Same as above	10
1330-1339	History of active energy in September	RO	Same as above	10
1340-1349	History of active energy in October	RO	Same as above	10
1350-1359	History of active energy in November	RO	Same as above	10
1360-1369	Historical December active energy	RO	Same as above	10
1370-1379	Total active energy	RO	Same as above	10
1500-1520	1 Time Zone Parameters		1 time zone is divided into 14 time periods; each time period occupies 1.5 words, the first byte is the hour, the second byte is the minute, the third byte is the rate type, the four rates are 0-tip, 1-peak, 2-even, 3-valley	
1521-1541	2 Time zone parameters		2 time zone is divided into 14 time periods; each time period occupies 1.5 words, the first byte is the hour, the second byte is the minute, the third byte is the rate type, the four rates are 0-tip, 1-peak, 2-even, 3-valley	
1542	Time zone type selection		Time zone selection, the high 12 bits correspond to 1-12 months time zone selection.	

			<p>For example, bit16: January time zone selection (0: select time zone 1, 1: select time zone 2).</p> <p>bit15: February time zone selection</p> <p>bit14: March time zone selection</p> <p>...</p> <p>Bit5: December time zone selection</p>	
--	--	--	--	--

3000 High Byte	Decimal Point U (DPT)	RO	3-7	0.5
3000 Low Byte	Decimal Point I (DCT)	RO	1-5	0.5
3001 High Byte	Decimal point PQ (DPQ)	RO	4-10	0.5
3001 Low Byte	Symbol PQ	RO	High - Low: Q, Qc, Qb, Qa, P, Pc, Pb, Pa 0 is positive, 1 is negative	0.5
3002	Phase voltage average	RO	Primary side	1
3003	Line voltage average	RO	One measurement	1
3004	Current average value	RO	One time side	1
3008-3009	System operation time	R/W	In seconds, high byte in front, low byte in back	2
3010	Phase voltage Uan maximum	RO	One time side	1
3011	Occurrence time: year, month	RO	High 8 bits: year; low 8 bits: month	1
3012	Occurrence time: day, hour	RO	High 8 bits: day; low 8 bits: hour	1
3013	Occurrence time: minutes, seconds	RO	High 8 bits: minutes; Low 8 bits: seconds	1
3014	Phase voltage Ubn max.	RO	Primary side	1
3015	Time of occurrence: year, month	RO	High 8 bits: year; Low 8 bits: month	1
3016	Occurrence time: day, hour	RO	High 8 bits: day; Low 8 bits: hour	1
3017	Occurrence time: minutes, seconds	RO	High 8 bits: minutes; Low 8 bits: seconds	1
3018	Phase voltage Ucn max.	RO	Primary side	1
3019	Occurrence time: year, month	RO	High 8 bits: year; Low 8 bits: month	1
3020	Occurrence time: day, hour	RO	High 8 bits: day; Low 8 bits: hour	1
3021	Occurrence time: minutes, seconds	RO	High 8 bits: minutes; Low 8 bits: seconds	1
3022	Line voltage Uab max.	RO	Primary side	1
3023	Occurrence time: year, month	RO	High 8 bits: year; Low 8 bits: month	1

3024	Occurrence time: day, hour	RO	High 8 bits: day; Low 8 bits: hour	1
3025	Occurrence time: minutes, seconds	RO	High 8 bits: minutes; Low 8 bits: seconds	1
3026	Line voltage Ubc max.	RO	Primary side	1
3027	Occurrence time: year, month	RO	High 8 bits: year; Low 8 bits: month	1
3028	Occurrence time: day, hour	RO	High 8 bits: day; Low 8 bits: hour	1
3029	Occurrence time: minutes, seconds	RO	High 8 bits: minutes; Low 8 bits: seconds	1
3030	Line voltage Uca max.	RO	Primary side	1
3031	Occurrence time: year, month	RO	High 8 bits: year; Low 8 bits: month	1
3032	Occurrence time: day, hour	RO	High 8 bits: Day; Low 8 bits: Hour	1
3033	Occurrence time: minutes, seconds	RO	High 8 bits: minutes; Low 8 bits: seconds	1
3034	Maximum phase current Ia	RO	Primary side	1
3035	Occurrence time: year, month	RO	High 8 bits: year; Low 8 bits: month	1
3036	Occurrence time: day, hour	RO	High 8 bits: day; Low 8 bits: hour	1
3037	Occurrence moment: minutes, seconds	RO	High 8 bits: minutes; Low 8 bits: seconds	1
3038	Maximum phase current Ib	RO	Primary side	1
3039	Time of occurrence: year, month	RO	High 8 bits: year; Low 8 bits: month	1
3040	Time of occurrence: day, hour	RO	High 8 bits: day; Low 8 bits: hour	1
3041	Occurrence moment: minutes, seconds	RO	High 8 bits: minutes; Low 8 bits: seconds	1
3042	Phase current Ic max.	RO	Primary side	1
3043	Time of occurrence: year, month	RO	High 8 bits: year; Low 8 bits: month	1
3044	Occurrence time: day, hour	RO	High 8 bits: day; Low 8 bits: hour	1
3045	Time of occurrence: minutes, seconds	RO	High 8 bits: minutes; Low 8 bits: seconds	1
3046	A-phase active power Pa max	RO	Primary side	1
3047	Time of occurrence: year, month	RO	High 8 bits: year; Low 8 bits: month	1
3048	Occurrence time: day, hour	RO	High 8 bits: day; Low 8 bits: hour	1
3049	Occurrence time: minutes, seconds	RO	High 8 bits: minutes; Low 8 bits: seconds	1
3050	B-phase active power Pb max.	RO	Primary side	1
3051	Occurrence time: year, month	RO	High 8 bits: year; Low 8 bits: month	1
3052	Occurrence time: day, hour	RO	High 8 bits: day; Low 8 bits: hour	1
3053	Occurrence time: minutes, seconds	RO	High 8 bits: minutes; Low 8 bits: seconds	1
3054	C-phase active power Pc	RO	Primary side	1

	maximum			
3055	Occurrence time: year, month	RO	High 8 bits: Year; Low 8 bits: Month	1
3056	Occurrence time: day, hour	RO	High 8 bits: day; Low 8 bits: hour	1
3057	Occurrence moment: minutes, seconds	RO	High 8 bits: minutes; Low 8 bits: seconds	1
3058	Total active power P total maximum	RO	Primary side	1
3059	Occurrence time: year, month	RO	High 8 bits: year; Low 8 bits: month	1
3060	Occurrence time: day, hour	RO	High 8 bits: day; Low 8 bits: hour	1
3061	Occurrence time: minutes, seconds	RO	High 8 bits: minutes; Low 8 bits: seconds	1
3062	The maximum value of reactive power Qa of phase A	RO	Primary side	1
3063	Occurrence time: year, month	RO	High 8 bits: year; Low 8 bits: month	1
3064	Occurrence time: day, hour	RO	High 8 bits: day; Low 8 bits: hour	1
3065	Occurrence time: minutes, seconds	RO	High 8 bits: minutes; Low 8 bits: seconds	1
3066	The maximum value of B-phase reactive power Qb	RO	Primary side	1
3067	Occurrence time: year, month	RO	High 8 bits: year; Low 8 bits: month	1
3068	Occurrence time: day, hour	RO	High 8 bits: day; Low 8 bits: hour	1
3069	Occurrence moment: minutes, seconds	RO	High 8 bits: minutes; Low 8 bits: seconds	1
3070	C-phase reactive power Qc maximum	RO	Primary side	1
3071	Occurrence time: year, month	RO	High 8 bits: year; Low 8 bits: month	1
3072	Occurrence time: day, hour	RO	High 8 bits: day; Low 8 bits: hour	1
3073	Occurrence time: minutes, seconds	RO	High 8 bits: minutes; Low 8 bits: seconds	1
3074	Total reactive power Q total maximum	RO	Primary side	1
3075	Occurrence time: year, month	RO	High 8 bits: year; Low 8 bits: month	1
3076	Occurrence time: day, hour	RO	High 8 bits: day; Low 8 bits: hour	1
3077	Occurrence time: minutes, seconds	RO	High 8 bits: minutes; Low 8 bits: seconds	1
3078	Maximum apparent power Sa of phase A	RO	Primary side	1
3079	Occurrence: year, month	RO	High 8 bits: year; Low 8 bits: month	1

3080	Time of occurrence: day, hour	RO	High 8 bits: day; Low 8 bits: hour	1
3081	Occurrence time: minutes, seconds	RO	High 8 bits: minutes; Low 8 bits: seconds	1
3082	B-phase apparent power Sb maximum	RO	Primary side	1
3083	Time of occurrence: year, month	RO	High 8 bits: year; Low 8 bits: month	1
3084	Occurrence time: day, hour	RO	High 8 bits: day; Low 8 bits: hour	1
3085	Occurrence time: minutes, seconds	RO	High 8 bits: minutes; Low 8 bits: seconds	1
3086	C-phase apparent power Sc maximum	RO	Primary side	1
3087	Time of occurrence: year, month	RO	High 8 bits: year; Low 8 bits: month	1
3088	Time of occurrence: day, hour	RO	High 8 bits: day; Low 8 bits: hour	1
3089	Occurrence moment: minutes, seconds	RO	High 8 bits: minutes; Low 8 bits: seconds	1
3090	Total apparent power S total maximum	RO	Primary side	1
3091	Time of occurrence: year, month	RO	High 8 bits: year; Low 8 bits: month	1
3092	Time of occurrence: day, hour	RO	High 8 bits: day; Low 8 bits: hour	1
3093	Occurrence time: minutes, seconds	RO	High 8 bits: minutes; Low 8 bits: seconds	1
3094	Maximum power factor of phase A	RO	Power Factor Number of decimal places: 3	1
3095	Occurrence: year, month	RO	High 8 bits: Year; Low 8 bits: Month	1
3096	Occurrence time: day, hour	RO	High 8 bits: day; Low 8 bits: hour	1
3097	Occurrence time: minutes, seconds	RO	High 8 bits: minutes; Low 8 bits: seconds	1
3098	B-phase power factor maximum	RO		1
3099	Occurrence time: year, month	RO	High 8: Year; Low 8: Month	1
3100	Occurrence time: day, hour	RO	High 8 bits: Day; Low 8 bits: Hour	1
3101	Occurrence moment: minutes, seconds	RO	High 8 bits: minutes; Low 8 bits: seconds	1
3102	C-phase power factor maximum	RO		1
3103	Occurrence time: year, month	RO	High 8 bits: year; Low 8 bits: month	1
3104	Occurrence time: day, hour	RO	High 8 bits: day; Low 8 bits: hour	1
3105	Occurrence time: minutes, seconds	RO	High 8 bits: minutes; Low 8 bits: seconds	1
3106	Frequency F max.	RO	Frequency decimal places: 2	1
3107	Time of occurrence: year, month	RO	High 8: Year; Low 8: Month	1
3108	Time of occurrence: day, hour	RO	High 8: Day; Low 8: Hour	1

3109	Occurrence moment: minutes, seconds	RO	High 8 bits: minutes; Low 8 bits: seconds	1
3110	Neutral line current max.	RO	Secondary side Current fractional digits: 3	1
3111	Time of occurrence: year, month	RO	High 8 bits: year; Low 8 bits: month	1
3112	Occurrence time: day, hour	RO	High 8 bits: day; Low 8 bits: hour	1
3113	Occurrence time: minutes, seconds	RO	High 8 bits: minutes; Low 8 bits: seconds	1
7392	Local IP address	R/W	High 8 bits: 198; Low 8 bits: 162	1
7393	Local IP address	R/W	High 8 bits: 0; Low 8 bits: 100	1
7394	Local subnet mask	R/W	High 8 bits: 255; Low 8 bits: 255	1
7395	Local subnet mask	R/W	High 8 bits: 255; Low 8 bits: 0	1
7396	Local gateway IP	R/W	High 8 bits: 192; Low 8 bits: 168	1
7397	Local Gateway IP	R/W	High 8 bits: 0; Low 8 bits: 1	1
7398	Local Port Number	R/W	Default 50000	1
7399-7401	MAC Address	RO		
8192	A-phase voltage	float	Primary side, in V	2
8194	B-phase voltage	float	Primary side, in V	2
8196	C-phase voltage	float	Primary side, in V	2
8198	Line voltage Uab	float	Primary side, in V	2
8200	Line voltage Ubc	float	Primary side, in V	2
8202	Line voltage Uca	float	Primary side, in V	2
8204	A-phase current	float	Primary side, in A	2
8206	B-phase current	float	Primary side, in A	2
8208	C-phase current	float	Primary side, in A	2
8212	Phase A active power	float	Primary power, in Kw	2
8214	Phase B active power	float	Primary power, in Kw	2
8216	C-phase active power	float	Primary power, in Kw	2
8218	Total active power P total	float	Primary power, in Kw	2
8220	Phase A reactive power Qa	float	Primary power, in Kvar	2
8222	Phase B reactive power Qb	float	Primary power, in Kvar	2
8224	Phase C reactive power Qc	float	Primary power, in Kvar	2
8226	Total reactive power Q total	float	Primary power, in Kvar	2
8228	Phase A apparent power Sa	float	Primary power, in KVA	2

8230	Phase B apparent power Sb	float	Primary power, in KVA	2
8232	Phase C apparent power Sc	float	Primary power, in KVA	2
8234	Total apparent power S total	float	Primary power, in KVA	2
8236	A-phase power factor	float		2
8238	B-phase power factor	float		2
8240	C-phase power factor	float		2
8242	Total power factor	float		2
8244	Frequency F	float		2
12418	正向有功电能一次值 EPI	float	In wh	2
12420	反向电能一次值 EPE	float	In wh	2
12424	正向无功电能一次值 EQL	float	In wh	2
12426	反向无功电能一次值 EQC	float	In wh	2

Note: 1. Read and write attributes: "RO" is read-only, and the command 0X03H is used for reading parameters; "R/W" is read-write, and the command 0X10H is used for writing system parameters, and it is forbidden to write data to addresses that are not listed or do not have writable attributes.

2. The meter data is expressed in fixed-point numbers, and the number of decimal places is shown in the address table.

7.5 Correspondence between communication value and actual value (The convention is that Val_t is the communication readout value and Val_s is the actual value)

7.5.1 Voltage, current, power factor, frequency

The measured values of the series are read out with command 03 of the Modbus-RTU communication protocol, each item occupying 1 word. the correspondence between the communication values and the actual primary side measured values is shown in the following table.

Applicable parameters	Correspondence	Unit
Voltage Uan, Ubn, Ucn, Uab, Ubc, Uca	$Val_s = Val_t * PU / U_e$	Volts V
Current IA, IB, IC	$Val_s = Val_t * PI / 1000$	Ampere A
Power factor value PFA, PFB, PFC, PF total	$Val_s = Val_t / 1000$	No unit
Frequency FR	$Val_s = Val_t / 100$	Hertz Hz

Example 1: Read A-phase voltage Uan, the data stored in the address 243 column can read the data, that is, communication read out value $Val_t = 3800$, read $PU = 100$, $U_e = 400$, then $Val_s = Val_t * PU / U_e = 3800 * 100 / 400 = 950V$.

Example 2: Read A-phase voltage Uan, the data is stored in the address 243 column can read the data, that is, communication read out value $Val_t = 3800$, read address 13-14 voltage factor Ratio = 0.25, then $Val_s = Val_t *$

Ratio = 3800 * 0.25 = 950V.

7.5.2 Active power, reactive power, apparent power and electrical energy

The measured values of this series are read out with command 0x03 of the Modbus-RTU communication protocol, and each item occupies two words. the correspondence between the communication value and the actual primary side value is as follows: $Val_s = Val_t / 100$; where $Val_t = \text{first word} \times 65536 + \text{second word}$.

Applicable parameters	Correspondence	Unit
Power	$Val_s = Val_t * PI * PU / Ue / 10$	W, var, VA
Electricity	$Val_s = Val_t * PI * PU / Ue/10$	kWh, kvarh

Example 1: Read A phase active power Pa, the data is stored at address 253~254: address 253 communication readout value is 0x0001, address 254 communication readout value is 0x6590, that is Val_t hexadecimal is 0x00016590, corresponding to signed decimal is 91536, read PU=100, PI=1000, Ue=400, then $Val_s = Val_t * PI * PU / Ue / 10 = 2288400W$.

Example 2: Read A phase active power Pa, the data is stored at address 253~254: address 253 communication readout value is 0xFFFFE, address 254 communication readout value is 0x9A70, that is, Val_t hexadecimal is 0xFFFFE9A70, corresponding signed decimal is -91536, read PU=100, PI=1000, Ue=400, then $Val_s = Val_t * PI * PU / Ue / 10 = -2288400W$.

Example 3: Read A phase active power Pa, the data is stored at address 253~254: address 253 communication readout value is 0x0001, address 254 communication readout value is 0x6590, that is, Val_t hexadecimal is 0x00016590, corresponding to signed decimal is 91536, address 18 communication readout value is 0x0000, address 19 communication readout value is 0x0019, that is, power energy coefficient Ratio hexadecimal is 0x00000019, Corresponding to the signed decimal is 25, then $Val_s = Val_t * Ratio = 2288400W$.

7.5.3 Voltage crest factor, telephone waveform factor, current K factor, voltage waveform peak, positive sequence and negative sequence zero sequence components of current and voltage, and unbalance degree

The measured values of this series are read out with command 0x03 of the Modbus-RTU communication protocol, and each item occupies 1 word. the correspondence between the communication values and the actual values is shown in the following table:

Applicable parameters	Correspondence	Unit
Voltage crest factor	$Val_s = Val_t / 1000$	No unit
Phone waveform factor	$Val_s = Val_t / 100$	No unit
Current K-factor	$Val_s = Val_t / 100$	No unit
Peak voltage (secondary side value)	$Val_s = Val_t / 10$	Volts V
Voltage and current unbalance degree	$Val_s = (Val_t / 10)\%$	Centimeter

Example: Read the A-phase voltage crest factor, MODSCAN can read the data in the address 0X011C column

in the Integer reading mode, that is, the communication reads the value Val_t as 1414, then Val_s = Val_t / 1000 = 1414/1000 = 1.414

7.5.4 Date and time

This series of measured values includes year, month, day, hour, minute and second, read out by command 03 of Modbus-RTU communication protocol, each item occupies 1 word, in BCD code format.

Example: Read the year, MODSCAN in HEX reading mode in the address 0X0081 column can be read directly.

7.5.5 Event Log

Event record 1 - event record 16, recorded in chronological order, that is, event record 1 records the data of the most recent event, event record 16 records the data of the earlier event, the data format of each event record is as follows:

	High 8 bits	Low 8 bits
Address 1	Bit 0 (lowest bit): 0 is DO, 1 is DI	Switching serial numbers.
Address 2	Bit 7 (highest bit): 0 for open, 1 for closed	0 for the first circuit, 1 for the second circuit, and so on
Address 3	Alarm type: see 6.2.6.4	Only the combination alarm is valid, see note
Address 4	Year (timestamp year)	Month (timestamp month)
Address 5	Day (timestamp day)	Hour (timestamp hour)
Address 6	The value at the time of alarm (the minimum value among the three phases is recorded when the phase is broken)	

Note: 0-Over line voltage, 1-Under line voltage, 2-Over frequency, 3-Under frequency, 4-Over power, 5-Under power, 6-Over current, 7-Under power factor
8-Over-voltage unbalance, 9-Over-current unbalance

Example: DO1 is the voltage alarm of phase A. If the undervoltage alarm occurs at 14:56:32 on 22/1/15, and the alarm value is 172.2V, the corresponding register value is as follows:

	High 8 bits	Low 8 bits
Address 1	8	0
Address 2	1	0
Address 3	15	1
Address 4	22	14
Address 5	56	32
Address 6	1722	

8 DL/T-645Communication Guide

The main focus is on how to use the software to control this series of meters through the communication port. To master the content, you need to have a knowledge base of DL/T645-1997 protocol and read through all the other chapters in this booklet to have a comprehensive understanding of the functions and application concepts of this

product. This chapter includes a brief description of the DL/T645-1997 protocol, a detailed explanation of the communication application format, details of the application of the machine and the parametric address table.

8.1 DL/T645-1997 Protocol Overview

The instrument uses a communication protocol that complies with the DL/T645-1997 specification, which defines in detail the checksum, data, sequence, etc., that are necessary for a particular data exchange. The DL/T645-1997 protocol uses a master-slave answering connection (half-duplex) on one communication line, which means that signals are transmitted on a single communication line along two opposite directions. First, the signal from the master computer is addressed to a unique terminal device (slave), and then the answer signal from the terminal device is transmitted in the opposite direction to the master.

The DL/T645-1997 protocol allows communication only between the master (PC, PLC, etc.) and the terminal devices, and does not allow data exchange between independent terminal devices, so that each terminal device does not occupy the communication line during their initialization, but is limited to responding to the query signal arriving at the local machine.

8.2 Transmission mode

A transmission method is a series of independent data structures within a data frame and the limited rules used to transmit the data, which are defined below and are compatible with the DL/T645-1997 protocol - RTU method.

Bits per byte

1 start bit

8 data bits, the least significant bit is sent first

1 even parity bit

1 stop bit

Error checking and parity

8.3 Protocol

When the data frame arrives at the end device, it enters the addressed device through a simple "port", which removes the "envelope" (data header) of the data frame, reads the data, and if there are no errors, performs the task for which the data was requested, then it adds the data it generated to the acquired "envelope" and returns the data frame to the sender. Then, it adds its own generated data to the obtained "envelope" and returns the data frame to the sender. The returned response data contains the following: the address of the terminal slave (Address), the executed command (Function), the requested data generated by the executed command (Data) and a check code (Check). Any error will not result in a successful response or an error indication frame will be returned.

9.3.1 Data frame format

68H	A 0	A1	A2	A3	A4	A 5	68H	C	L	DI0	DI1	N1	...	Nm	CS	16H
Start Character	Address Field					Start Frame	of Control Code	Data Length	Data Identificati on	Data					Checksu m	End Charact er

a) Frame start character 68H

Identifies the start of a frame with a value of 68H

b) Address field A0~A5

The address field consists of 6 bytes (8-bit binary code), with 2 bits of BCD code per byte. The address length can be up to 12 decimal digits, ACR10R

Only A0 and A1 are used, where A0 is the low byte of the address and A1 is the high byte of the address, consisting of an address range of 1 to 247, and this address data can be set arbitrarily in the instrument. The rest (A2 to A5) are all filled with 00. These bits mark the address of the user-specified terminal device that will receive data from the host to which it is connected. The address of each terminal device must be unique, and only the terminal addressed will respond to a query containing that address. When a terminal sends back a response, the slave address data in the response tells the host which terminal is communicating with it. When the address is 99999999999999H, it is a broadcast address.

c) Control Code C

The function field codes tell what function is performed by the terminal being addressed. The following table lists the function codes used in this series of meters, along with their meaning and function.

Code	Meaning	Behavior
01H	Read Data	Reading data from the ACR10R
81H	Read Data Answer	ACR10R's response to read data
04H	Write data	Writing data to the ACR10R
84H	Write Data Answer	ACR10R answer to write data
C4H or C2H	Error response	Received data error

d) Length of the data field (data identifier and data) L

The length of the byte of the data field. $L \leq 200$ when reading data, ≤ 50 when writing data, $L = 0$ means no data field.

e) Error check CS

The sum of all bytes modulo 256 from the start of the frame to the check digit, i.e. the binary arithmetic sum of each byte, not counting the overflow value over 256.

f) End character 16H

Identifies the end of a data frame

9.3.2 Transmission

a) Leading byte

Before sending the frame information, 1 to 4 bytes of FEH can be transmitted to wake up the receiver

b) Transmission order

All data items are transmitted with the low byte first, followed by the high byte. The transmitted data items (except for the switching quantity) are the compressed BCD code of the actual data plus 33H. For example, the external host reads the ACR10R's forward active energy meter address as 1.

Host sends: FE FE 68 01 00 00 00 00 68 01 02 43 C3 DA 16

ACR10R response (0.40kWh): 68 01 00 00 00 00 00 68 81 06 43 C3 73 33 33 33 6A 16

c) Transmission response

Each communication is started by the master sending a request command frame to the slave selected by the address field of the information frame, and the requested slave responds according to the requirements of the control code in the command frame.

Response delay after receiving a command frame: $\leq 500\text{ms}$

Pause time between bytes: ≤ 6 bytes of sending time, when this time is exceeded, the ACR10R considers it a new data frame.

d) Error control

The byte checksum is even, and the frame checksum is longitudinal information checksum. If the receiver detects an error in even or longitudinal information checksum, the frame is dropped and no response is given.

e) Transmission rate

The initial rate is: 9600bps

Can be set to 1200, 2400, 4800, 9600, 19200bps

Data identification table

Table 1

Serial number	Variable name	Sending sample (broadcast address as an example, user can set according to the actual needs, the high bit of the address is filled with "000000")	Return words Number of sections	Return data format (Secondary measurement)	Return data units
1	Positive active energy	68 99 99 99 99 99 99 68 01 02 43 C3 6F 16	4	XXXXXX. XXkWh	
2	Reverse active energy	68 99 99 99 99 99 99 68 01 02 53 C3 7F 16	4	XXXXXX. XXkWh	
3	Inductive reactive energy	68 99 99 99 99 99 99 68 01 02 43 C4 70 16	4	XXXXXX. XXkvarh	
4	Capacitive reactive energy	68 99 99 99 99 99 99 68 01 02 53 C4 80 16	4	XXXXXX. XXkvarh	
5	A-phase voltage	68 99 99 99 99 99 99 68 01 02 44 E9 96 16	2	XXX	V
6	B-phase voltage	68 99 99 99 99 99 99 68 01 02 45 E9 97 16	2	XXX	V
7	C-phase voltage	68 99 99 99 99 99 99 68 01 02 46 E9 98 16	2	XXX	V
8	Voltage vector and	68 99 99 99 99 99 99 68 01 02 4A E9 9C 16	2	XXX	V
9	Grid frequency	68 99 99 99 99 99 99 68 01 02 4B E9 9D 16	2	XX. XX	Hz
10	A-phase current	68 99 99 99 99 99 99 68 01 02 54 E9 A6 16	2	XX. XX	A
11	B-phase current	68 99 99 99 99 99 99 68 01 02 55 E9 A7 16	2	XX. XX	A
12	C-phase current	68 99 99 99 99 99 99 68 01 02 56 E9 A8 16	2	XX. XX	A
13	Current vector and	68 99 99 99 99 99 99 68 0102 5A E9 AC 16	2	XX. XX	A
14	Combined phase active power	68 99 99 99 99 99 99 68 01 02 63 E9 B5 16	3	XX. XXXX	kW
15	Phase A active	68 99 99 99 99 99 99 68 01 02 64 E9 B6 16	3	XX. XXXX	kW

	power				
16	Phase B active power	68 99 99 99 99 99 99 68 01 02 65 E9 B7 16	3	XX. XXXX	kW
17	C-phase active power	68 99 99 99 99 99 99 68 01 02 66 E9 B8 16	3	XX. XXXX	kW
18	Phase A reactive power	68 99 99 99 99 99 99 68 01 02 73 E9 C5 16	2	XX. XX	kvar
19	Phase A reactive power	68 99 99 99 99 99 99 68 01 02 74 E9 C6 16	2	XX. XX	kvar
20	Phase B reactive power	68 99 99 99 99 99 99 68 01 02 75 E9 C7 16	2	XX. XX	kvar
21	C-phase reactive power	68 99 99 99 99 99 99 68 01 02 76 E9 C8 16	2	XX. XX	kvar
22	Combined phase power factor	68 99 99 99 99 99 99 68 01 02 83 E9 D5 16	2	X. XXX	
23	Phase A power factor	68 99 99 99 99 99 99 68 01 02 84 E9 D6 16	2	X. XXX	
24	Phase B power factor	68 99 99 99 99 99 99 68 01 02 85 E9 D7 16	2	X. XXX	
25	C-phase power factor	68 99 99 99 99 99 99 68 01 02 86 E9 D8 16	2	X. XXX	
26	Date of reading	68 99 99 99 99 99 99 68 01 02 43 F3 9F 16	4	YYMMDDWW	WW=00
27	Reading time	68 99 99 99 99 99 99 68 01 02 44 F3 A0 16	3	hhmmss	
28	Switching status value	68 99 99 99 99 99 99 68 01 02 56 F3 B2 16	1		See Attachment 1
29	Voltage multiplier	68 99 99 99 99 99 99 68 01 02 68 F3 C4 16	2	XXXX	
30	Current multiplier	68 99 99 99 99 99 99 68 01 02 69 F3 C5 16	2	XXXX	
31	Clear switch output	68 99 99 99 99 99 99 68 04 03 56 F3 00 B6 16	0		Switching output has 4 channels: DO1-D04
32	Set DO1	68 99 99 99 99 99 99 68 04 03 56 F3 01 B7 16	0		
33	设置 DO2	68 99 99 99 99 99 99 68 04 03 56 F3 02 B8 16	0		
34	设置 DO1、DO2	68 99 99 99 99 99 99 68 04 03 56 F3 03 B9 16	0		

Attachment 1:

Bit7	Bit6	Bit5	Bit4	Bit3	Bit2	Bit1	Bit0
DI1	DI2	DI3	DI4	DO1	DO2	DO3	DO4

Headquarters: Acrel Co., LTD.

Address: No.253 Yulv Road Jiading District, Shanghai, China

TEL.: 0086-13774416773

WhatsApp: 0086-13774416773

Web-site: acrel.se

mail: Daisylin@acrel-electric.com

Postcode: 201801

Manufacturer: Jiangsu Acrel Electrical Manufacturing Co., LTD.

Address: No.5 Dongmeng Road,Dongmeng industrial Park, Nanzha Street,Jiangyin City,Jiangsu
Province,China

Postcode: 214405