

AMC100 AC Precision power distribution monitoring device

Installation instruction V1. 3

Marketing Manager: Daisylin li WhatsApp: +8613774416773 Tel: +8613774416773
E-mail: Daisylin@acrel-electric.com Web: acrel-electric.se

Acrel Co., Ltd

Marketing Manager: Daisylin li WhatsApp: +8613774416773 Tel: +8613774416773
E-mail: Daisylin@acrel-electric.com Web: acrel-electric.se

Declaration

All rights reserved. Without the written permission of the company, any paragraph or chapter in this manual shall not be cut, copied or transmitted in any form. Otherwise, all consequences shall be borne by the violator.

All legal rights are reserved.

The company reserves the right to modify the product specifications described in this manual without prior notice. Please contact your local agent for new specifications before

ordering.

Content

1 General	1
2 Product Model	1
3 Technical Parameters	2
4 Appearance and structure	6
5 Wiring Terminals	6
5.1 AMC100-ZA Series	6
5.2 AMC100-FA30/FA48	9
5.3 AMC100-FAK30/FAK48	11
5.4 AMC100-KA30/KA48	12
5.5 AMC100-KD30/KD48	14
5.6 AMC100-FT30/FT48	15
6 Touch Screen	17
6.1 Appearance and installation	18
6.2 Wiring	19
7 Details of parameters, functions, and operations	20
7.1 Incoming Line Parameters	21
7.2 Outgoing parameters	24
7.3 Switch state	25
7.3.1 Main switch state	25
7.3.2 Branch switch state	25
7.4 Alarm query	25
7.4.1 Current alarms	25
7.4.3 Alarm Count	27
7.4.4 Alarm Value Query	27
7.5 User login	27
7.6 Time setting	28
7.7 System Settings	29
7.7.1 Number of loops Setting	29
7.7.2 Line load related	31
7.7.3 Outgoing switch rating	32
7.7.4 Outgoing current transformation ratio	32
7.7.5 Outlet name	33
7.8 Alarm settings	34
7.8.1 Incoming line alarm setting	34
7.8.2 Outgoing Line alarm setting	36
7.8.3 Communication alarm	37
7.9 Data Clearing	39
7.10 Background communication	40

1 General

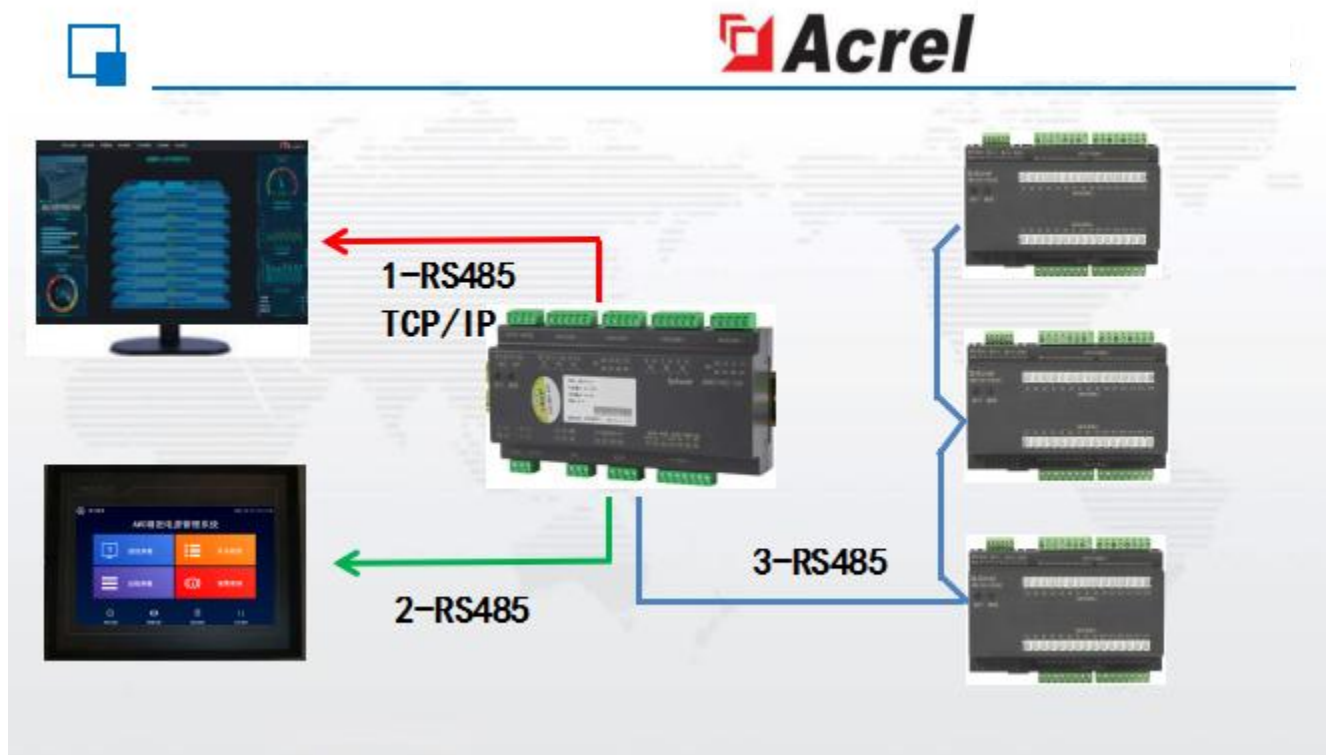

With the rapid development of data centers, the energy consumption of data centers has become more and more prominent. Energy management and power supply and distribution design of data centers have become hot issues. An efficient and reliable data center power distribution system solution is to improve data centers. Electric energy use efficiency, an effective way to reduce equipment energy consumption. To achieve energy saving in the data center, it is first necessary to monitor each electrical load, and there are many load loops in the data center. Traditional measuring instruments cannot meet the requirements of cost, volume, installation, construction and other aspects. Therefore, it is necessary to adopt suitable data Multi-loop monitoring device required by central centralized monitoring.

Acrel AMC100 series AC precision power distribution monitoring device is a measuring device designed specifically for power management of data center servers. The device is compact in design and can monitor the full electrical parameters, input and output switches and the status of the lightning arrester of A+B two incoming lines and 192 outgoing lines in real time. The alarm thresholds of all measurement channels can be set individually, and the outgoing line The limited event immediately triggers the system's sound and light alarms, and the high integration of the monitoring loop is realized in the volume of the traditional instrument.

2 Product Model

Model	Function Description
AMC100-ZA	Monitoring the full power parameters of the A+B dual three-phase AC incoming circuit, 8 switching status inputs, 4 switching status outputs, 2 leakage monitoring, 1 temperature and humidity detection, 3 RS485 communications
AMC100-FAK30	Monitor the full power parameters and switch status of a total of 30branches of A+B dual AC outlets, and 1 RS485 communication
AMC100-FAK48	Monitor the full power parameters and switch status of a total of 48branches of A+B dual AC outlets, and 1 RS485 communication
AMC100-FA30	Monitor the full power parameters of a total of 30branches of A+B dual AC outlets, and 1 RS485 communication
AMC100-FA48	Monitor the full power parameters of a total of 48branches of A+B dual AC outlets, and 1 RS485 communication
AMC100-KA30	Wet contact, monitor the switching status of 30branches A+B, 1 RS485 communication
AMC100-KA48	Wet contact, monitor the switching status of 48branches A+B, 1 RS485 communication
AMC100-KD30	Dry contact, monitor the switching status of 30branches A+B, 1 RS485 communication

AMC100-KD48	Dry contact, monitor the switching status of 48branches A+B, 1 RS485 communication
AMC100-FT30	1 way RS485 communication, 30 way temperature measurement
AMC100-FT48	1 way RS485 communication, 48 way temperature measurement

3 Technical Parameters

AC incoming line

Instrument model		AMC100-ZA
Measurement parameters		Voltage, current, frequency, active power, reactive power, power factor, active energy, reactive energy, Zero-to-ground voltage, leakage current and zero sequence current, total harmonic content (THD), 2-63 harmonics, current and voltage unbalance, ambient temperature and humidity
Bus voltage	Rated	220VAC
	Measuring range	±20%
	Overload	Instantaneous voltage 2 times/sec
Current incoming circuit	Rated	Secondary 5 A
	Range	0~6 A
	Overload	Continuous 1.2 times, instantaneous 10 times/sec
Temperature and humidity	Temperature Range	-40°C~+99°C
	Humidity Range	20%~90%
Input frequency		AC45~65 Hz
Measurement accuracy	Incoming line	Voltage/current level 0.2, active power/energy level 0.5, reactive power/energy level 1
	Temperature	±1°C
	Humidity	±5%
Auxiliary power		AMC100-ZA: signal to take power (≤15W) AMC100-ZA-P220: 220V independent power supply AMC100-ZA-P24: DC 12-24V independent power supply
Environment	Temperature	Work: -20°C~150°C Storage: -25°C~70°C
	Humidity	Relative humidity≤93%
	elevation	≤2500m
Switch output		4 channels 3A 250VAC/3A 30VDC
Switch input		8 dry nodes
Communication		1 isolated RS485/Modbus-RTU to the background system 1 RS485/Modbus-RTU to touch screen 1 RS485/Modbus-RTU connection downstream module Optional 1-channel Ethernet communication function
Installation Method		DIN35 mm rail or bottom plate installation
Protection level		IP20
Pollution level		2
Security	Insulation	The insulation resistance between all terminals and the conductive parts of the shell is not less than 100MΩ
	Withstand voltage	A voltage and current signal//B voltage and current signal//switch output//isolated communication port//between other ports meet AC2kV 1min, switch input and other ports should meet AC0.5kV 1min, leakage current Should be less than 2mA, no breakdown or flashover phenomenon.
Electromagnet	Anti- static	Level 4

ic compatibility	interference	
	Anti- electric fast transient burst	Level 3
	Anti- surge interference	Level 4
	Resistance to radio frequency electromagnetic field radiation	Level 3

AC outlet

Instrument model		AMC100-FA30	AMC100-FA48
Measurement parameters		Voltage, current, frequency, active power, reactive power, power factor, active energy, reactive energy, 2-3 1 times total current harmonic content	
Bus voltage	Rated	220VAC	
	Measuring range	±20%	
	Overload	Instantaneous voltage 2 times/sec	
Current outlet loop	Rated	50mA	
	Range	0. 125~60mA	
	Overload	Continuous 1.2 times, instantaneous 10 times/sec	
Input frequency		AC45~65 Hz	
Measure	Outlet	Voltage/current/active power/active energy level 0.5, reactive power/reactive energy level 1	
Auxiliary power		Powered by AMC100-ZA; DC 12-24V power supply when used alone	
Environment	Temperature	Work: - 15°C~55°C Storage: -25°C~70°C	
	Humidity	Relative humidity≤93%	
	elevation	≤2500m	
Communication		RS485/Modbus-RTU	
Installation Method		DIN35 mm rail or bottom plate installation	
Protection level		IP20	
Pollution level		2	
Security	Insulation	The insulation resistance between all terminals and the conductive parts of the shell is not less than 100MΩ	
	Withstand voltage	The voltage and current signals of circuit A//the voltage and current signals of circuit B//other ports meet AC2kV for 1min, the leakage current should be less than 2mA, and there is no breakdown or flashover.	
Electromagnetic compatibility	Anti- static interference	Level 4	
	Resistance to radio frequency electromagnetic field radiation	Level 3	

Note: The rated input current of the secondary side of the AC outlet module is 50mA, and the default value of the primary side current is 100A. If the current transformer is different, the customer can set the transformation ratio through the touch screen or the host computer according to the actual use.

Instrument model		AMC100-FAK30	AMC100-FAK48
Measurement parameters		Voltage, current, frequency, active power, reactive power, power factor, active energy, reactive energy, 2-31 times total current harmonic content	
Bus voltage	Rated	220VAC	
	Measuring range	±20%	
	Overload	Instantaneous voltage 2 times/sec	
Current outlet loop	Rated	50mA	
	Range	0.125~60mA	
	Overload	Continuous 1.2 times, instantaneous 10 times/sec	
Input frequency		AC45~65 Hz	
Measure	Outlet	Voltage/current/active power/active energy level 0.5, reactive power/reactive energy level 1	
Auxiliary power		Powered by AMC100-ZA; DC 12-24V power supply when used alone	
Environment	Temperature	Work: -15°C~55°C Storage: -25°C~70°C	
	Humidity	Relative humidity≤93%	
	elevation	≤2500m	
Communication		RS485/Modbus-RTU	
Installation Method		DIN35mm rail or bottom plate installation	
Protection level		IP20	
Pollution level		2	
Security	Insulation	The insulation resistance between all terminals and the conductive parts of the shell is not less than 100MΩ	
	Withstand voltage	The voltage and current signals of circuit A// the voltage and current signals of circuit B// other ports meet AC2 kV for 1 min, the leakage current should be less than 2 mA, and there is no breakdown or flashover.	
Electromagnetic compatibility	Anti-static interference	Level 4	
	Resistance to radio frequency electromagnetic field radiation	Level 3	

Note: The rated input current of the secondary side of the AMC100-FAK module is 50mA, and the default value of the primary side current is 100 A. If the current transformer is different, the customer can set the transformation ratio through the touch screen or the host computer according to the actual use.

Active switch module

Instrument model		AMC100-KA30	AMC100-KA48
Input frequency		45-65Hz AC45-65Hz	
Auxiliary power		Powered by AMC100-ZA, DC 12-24V power supply when used alone	
Environment	Temperature	Work: -15°C~55°C Storage: -25°C~70°C	
	Humidity	Relative humidity≤93%	
	elevation	≤2500m	
Switch input		30 wet nodes (AC 220V)	48 wet nodes (AC 220V)
Communication		RS485/Modbus-RTU	
Installation Method		DIN35mm rail or bottom plate installation	

Protection level		IP20
Pollution level		2
Security	Insulation	The insulation resistance between all terminals and the conductive parts of the shell is not less than 100MΩ
	Withstand voltage	A switch value input signal// B switch value input signal// other ports meet AC2 kV 1 min between two, the leakage current should be less than 2 mA, no breakdown or flashover phenomenon.
Electromagnetic compatibility	Anti- static interference	Level 4
	Resistance to radio frequency electromagnetic field radiation	Level 3

Passive switch module

Instrument model		AMC100-KD30	AMC100-KD48
Auxiliary power		Powered by AMC100-ZA, DC 12-24V power supply when used alone	
Environment	Temperature	Work: - 15°C~55°C Storage: -25°C~70°C	
	Humidity	Relative humidity≤93%	
	elevation	≤2500m	
Switch input		30-way trunk node	48-way trunk node
Communication		RS485/Modbus-RTU	
Installation Method		DIN35 mm rail or bottom plate installation	
Protection level		IP20	
Pollution level		2	
Security	Insulation	The insulation resistance between all terminals and the conductive parts of the shell is not less than 100MΩ	
	Withstand voltage	A switch value input signal// B switch value input signal// other ports meet AC2 kV 1 min between two, the leakage current should be less than 2 mA, no breakdown or flashover phenomenon.	
Electromagnetic compatibility	Anti- static interference	Level 4	
	Resistance to radio frequency electromagnetic field radiation	Level 3	

Temperature measurement module

Instrument model		AMC100-FT30	AMC100-FT48
Number of measuring channels		30 channels	48 channels
Auxiliary power		Powered by AMC100-ZA, DC 12-24V power supply when used alone	
Function	Temperature Range	-20°C~150°C	
	Communication	RS485/Modbus-RTU	
Installation Method		DIN35 mm rail or bottom plate installation	
Protection level		IP20	
Pollution level		2	

Environment	Temperature/humidity / elevation	Working temperature: -20℃~60℃ Storage temperature: -25℃~70℃ Relative humidity: ≤93% Altitude: ≤2500m
Security	Insulation	The insulation resistance between all terminals and the conductive parts of the shell is not less than 100MΩ
	Withstand voltage	AC2 kV 1 min between auxiliary power supply and temperature measurement, leakage current should be less than 2 mA, no breakdown or flashover phenomenon
Electromagnetic compatibility	Anti- static interference	Level 4
	Resistance to radio frequency electromagnetic Field radiation	Level 3

4 Appearance and structure

AMC100 series AC precision power distribution monitoring device
 AMC100-ZA、AMC100-FA□48、AMC100-K□48、AMC100-FT48

unit:mm

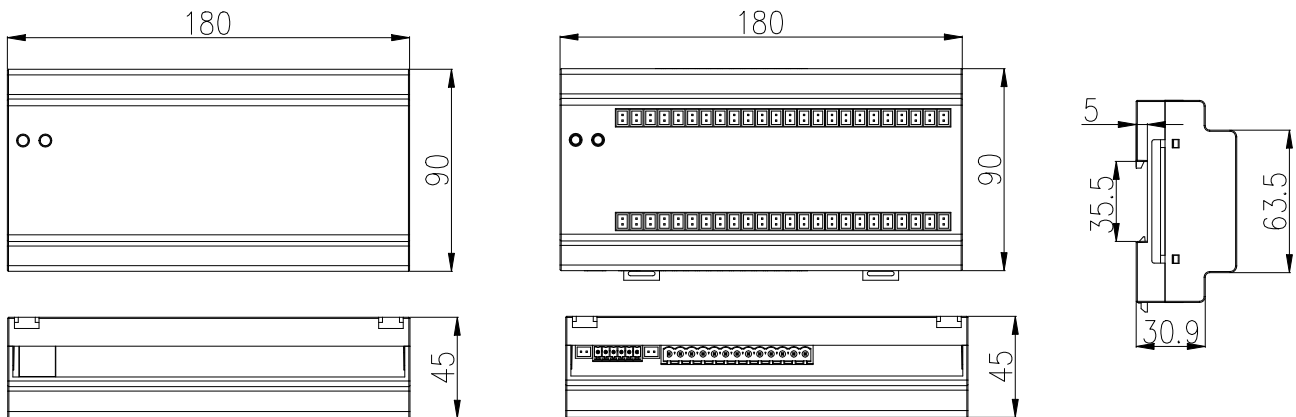

AMC100-FA□30、AMC100-K□30、AMC100-FT30

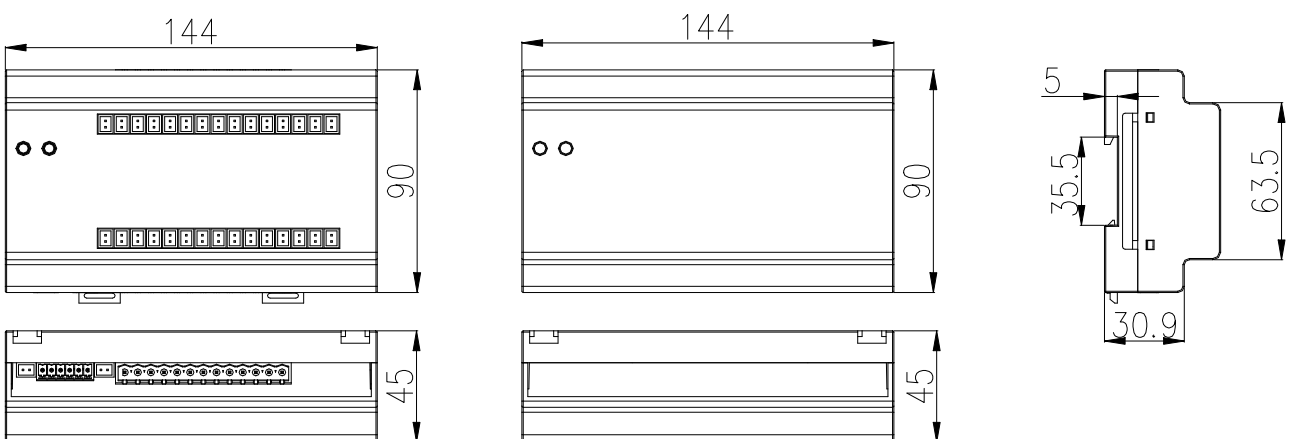

5 Wiring Terminals

5.1 AMC100-ZA Series

AMC100-ZA

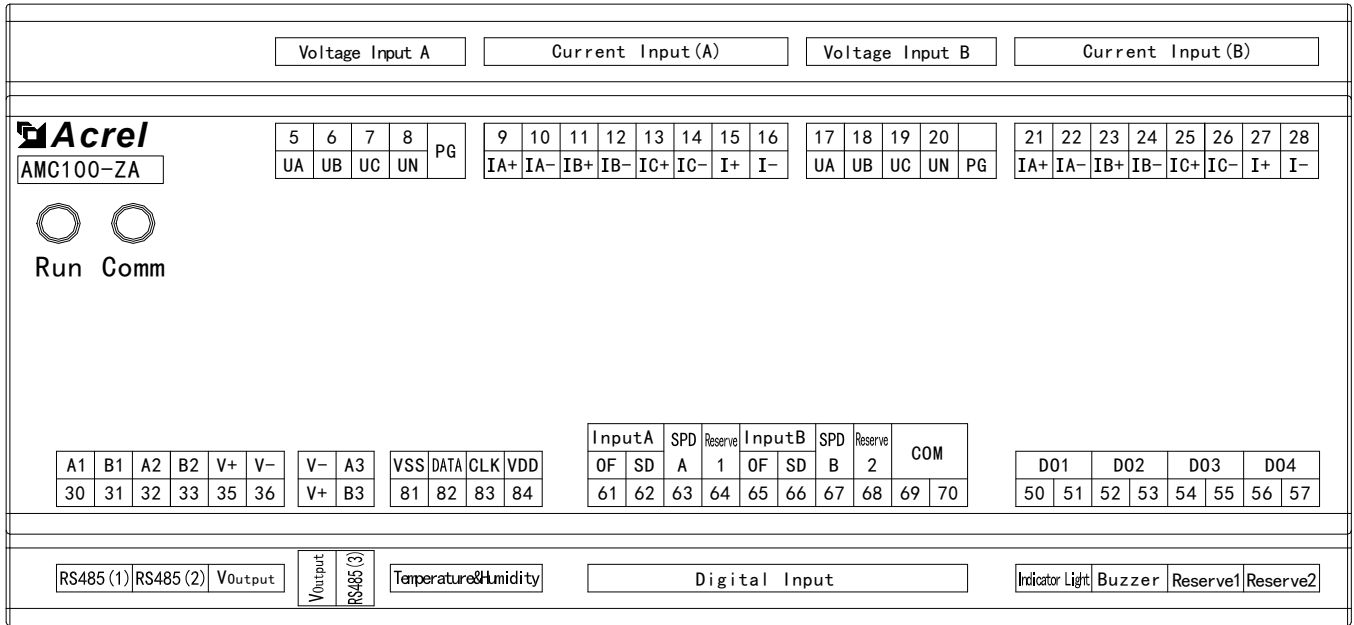

AMC100-ZA/CE-P220

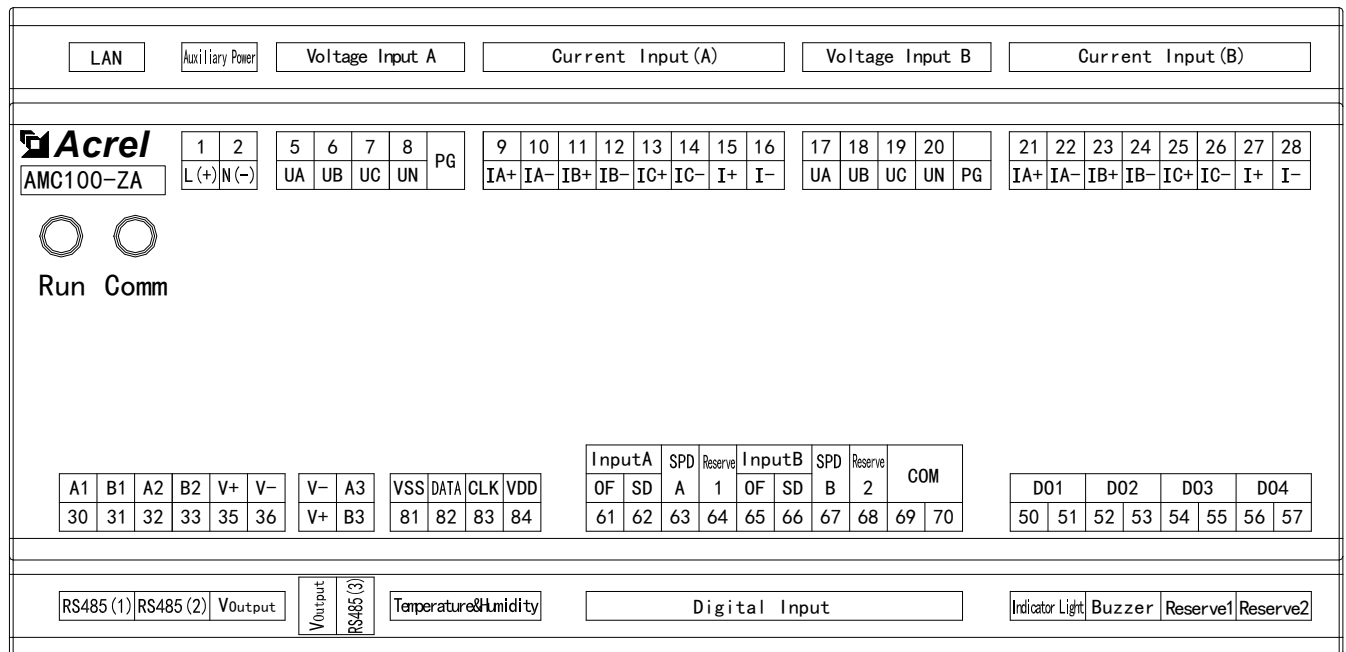

AMC100-ZA/CE-P24

LAN	Voltage Input A	Current Input (A)	Voltage Input B	Current Input (B)																																																					
<table style="width:100%; border-collapse: collapse;"> <tr> <td style="width:5%; text-align:center;">5</td><td style="width:5%; text-align:center;">6</td><td style="width:5%; text-align:center;">7</td><td style="width:5%; text-align:center;">8</td><td style="width:5%; text-align:center;">PG</td> <td style="width:5%; text-align:center;">9</td><td style="width:5%; text-align:center;">10</td><td style="width:5%; text-align:center;">11</td><td style="width:5%; text-align:center;">12</td><td style="width:5%; text-align:center;">13</td><td style="width:5%; text-align:center;">14</td><td style="width:5%; text-align:center;">15</td><td style="width:5%; text-align:center;">16</td> <td style="width:5%; text-align:center;">17</td><td style="width:5%; text-align:center;">18</td><td style="width:5%; text-align:center;">19</td><td style="width:5%; text-align:center;">20</td><td style="width:5%; text-align:center;"> </td> <td style="width:5%; text-align:center;">21</td><td style="width:5%; text-align:center;">22</td><td style="width:5%; text-align:center;">23</td><td style="width:5%; text-align:center;">24</td><td style="width:5%; text-align:center;">25</td><td style="width:5%; text-align:center;">26</td><td style="width:5%; text-align:center;">27</td><td style="width:5%; text-align:center;">28</td> </tr> <tr> <td style="text-align:center;">UA</td><td style="text-align:center;">UB</td><td style="text-align:center;">UC</td><td style="text-align:center;">UN</td><td style="text-align:center;">PG</td> <td style="text-align:center;">IA+</td><td style="text-align:center;">IA-</td><td style="text-align:center;">IB+</td><td style="text-align:center;">IB-</td><td style="text-align:center;">IC+</td><td style="text-align:center;">IC-</td><td style="text-align:center;">I+</td><td style="text-align:center;">I-</td> <td style="text-align:center;">UA</td><td style="text-align:center;">UB</td><td style="text-align:center;">UC</td><td style="text-align:center;">UN</td><td style="text-align:center;">PG</td> <td style="text-align:center;">IA+</td><td style="text-align:center;">IA-</td><td style="text-align:center;">IB+</td><td style="text-align:center;">IB-</td><td style="text-align:center;">IC+</td><td style="text-align:center;">IC-</td><td style="text-align:center;">I+</td><td style="text-align:center;">I-</td> </tr> </table>					5	6	7	8	PG	9	10	11	12	13	14	15	16	17	18	19	20		21	22	23	24	25	26	27	28	UA	UB	UC	UN	PG	IA+	IA-	IB+	IB-	IC+	IC-	I+	I-	UA	UB	UC	UN	PG	IA+	IA-	IB+	IB-	IC+	IC-	I+	I-	
5	6	7	8	PG	9	10	11	12	13	14	15	16	17	18	19	20		21	22	23	24	25	26	27	28																																
UA	UB	UC	UN	PG	IA+	IA-	IB+	IB-	IC+	IC-	I+	I-	UA	UB	UC	UN	PG	IA+	IA-	IB+	IB-	IC+	IC-	I+	I-																																
 Run Comm																																																									
<table style="width:100%; border-collapse: collapse;"> <tr> <td style="width:5%; text-align:center;">A1</td><td style="width:5%; text-align:center;">B1</td><td style="width:5%; text-align:center;">A2</td><td style="width:5%; text-align:center;">B2</td><td style="width:5%; text-align:center;">V+</td><td style="width:5%; text-align:center;">V-</td> <td style="width:5%; text-align:center;">V-</td><td style="width:5%; text-align:center;">A3</td> <td style="width:5%; text-align:center;">VSS</td><td style="width:5%; text-align:center;">DATA</td><td style="width:5%; text-align:center;">CLK</td><td style="width:5%; text-align:center;">VDD</td> <td style="width:5%; text-align:center;">InputA</td><td style="width:5%; text-align:center;">SPD</td><td style="width:5%; text-align:center;">Reserve</td><td style="width:5%; text-align:center;">InputB</td><td style="width:5%; text-align:center;">SPD</td><td style="width:5%; text-align:center;">Reserve</td> <td style="width:5%; text-align:center;">COM</td> <td style="width:5%; text-align:center;">D01</td><td style="width:5%; text-align:center;">D02</td><td style="width:5%; text-align:center;">D03</td><td style="width:5%; text-align:center;">D04</td> </tr> <tr> <td style="text-align:center;">30</td><td style="text-align:center;">31</td><td style="text-align:center;">32</td><td style="text-align:center;">33</td><td style="text-align:center;">35</td><td style="text-align:center;">36</td> <td style="text-align:center;">V+</td><td style="text-align:center;">B3</td> <td style="text-align:center;">81</td><td style="text-align:center;">82</td><td style="text-align:center;">83</td><td style="text-align:center;">84</td> <td style="text-align:center;">OF</td><td style="text-align:center;">SD</td><td style="text-align:center;">A</td><td style="text-align:center;">1</td><td style="text-align:center;">OF</td><td style="text-align:center;">SD</td><td style="text-align:center;">B</td><td style="text-align:center;">2</td> <td style="text-align:center;">69</td><td style="text-align:center;">70</td> <td style="text-align:center;">50</td><td style="text-align:center;">51</td><td style="text-align:center;">52</td><td style="text-align:center;">53</td><td style="text-align:center;">54</td><td style="text-align:center;">55</td><td style="text-align:center;">56</td><td style="text-align:center;">57</td> </tr> </table>					A1	B1	A2	B2	V+	V-	V-	A3	VSS	DATA	CLK	VDD	InputA	SPD	Reserve	InputB	SPD	Reserve	COM	D01	D02	D03	D04	30	31	32	33	35	36	V+	B3	81	82	83	84	OF	SD	A	1	OF	SD	B	2	69	70	50	51	52	53	54	55	56	57
A1	B1	A2	B2	V+	V-	V-	A3	VSS	DATA	CLK	VDD	InputA	SPD	Reserve	InputB	SPD	Reserve	COM	D01	D02	D03	D04																																			
30	31	32	33	35	36	V+	B3	81	82	83	84	OF	SD	A	1	OF	SD	B	2	69	70	50	51	52	53	54	55	56	57																												
<table style="width:100%; border-collapse: collapse;"> <tr> <td style="width:10%; text-align:center;">RS485 (1)</td><td style="width:10%; text-align:center;">RS485 (2)</td><td style="width:10%; text-align:center;">VInput</td> <td style="width:10%; text-align:center;">VOutput</td><td style="width:10%; text-align:center;">RS485 (3)</td> <td style="width:10%; text-align:center;">Temperature&Humidity</td> <td style="width:10%; text-align:center;">Digital Input</td> <td style="width:10%; text-align:center;">Indicator Light</td><td style="width:10%; text-align:center;">Buzzer</td><td style="width:10%; text-align:center;">Reserve1</td><td style="width:10%; text-align:center;">Reserve2</td> </tr> </table>					RS485 (1)	RS485 (2)	VInput	VOutput	RS485 (3)	Temperature&Humidity	Digital Input	Indicator Light	Buzzer	Reserve1	Reserve2																																										
RS485 (1)	RS485 (2)	VInput	VOutput	RS485 (3)	Temperature&Humidity	Digital Input	Indicator Light	Buzzer	Reserve1	Reserve2																																															

Terminal number	Definition	Description	Remark
1	L(+)	Auxiliary power	P220 used, not connected by default
2	N(-)		
5	UA	AC voltage Phase A	Three-phase voltage input of circuit A incoming line
6	UB	AC voltage Phase B	
7	UC	AC voltage Phase C	
8	UN	AC voltage neutral line	
PG		Ground	
9	IA+	Current input phase A	Three-phase current input of circuit A incoming line
10	IA-		
11	IB+	Current input phase B	
12	IB-		
13	IC+	Current input phase C	
14	IC-		
15	I+	A channel leakage current input	
16	I-		
17	UA	AC voltage Phase A	Three-phase voltage input of circuit B incoming line
18	UB	AC voltage Phase B	
19	UC	AC voltage Phase C	
20	UN	voltage neutral line	
PG		Ground	
21	IA+	Current input phase A	Three-phase current input of circuit B incoming line
22	IA-		
23	IB+	Current input phase B	
24	IB-		
25	IC+	Current input phase C	
26	IC-		
27	I+	B channel leakage current input	
28	I-		
30	A1	RS485(1)	The first isolated communication interface, connected to the background system
31	B1		
32	A2	RS485(2)	The second channel is connected to the touch

33	B2		screen or RS485 hub
	A3	RS485(3)	The third way is connected to the downstream module
	B3		
	LAN	Ethernet	CE with Ethernet communication
35	V+	Power Output (auxiliary power input when use p24)	Power supply to AMC100-FA30/48,
36	V-		AMC100-FAK30/48,AMC100-KA30/48,AMC100-KD30/48,AMC100-FT30/FT48 and touch screen, this power supply prohibits external external devices (such as indicator lights, buzzers)
50	DO1	Switch output	Connect the buzzer
51			
52	DO2		Connection indicator
53			
54	DO3		Reserved 1
55			
56	DO4		Reserved 2
57			
61	Incoming line A	Switch input	OF
62			SD
63	Lightning protection A		Determine the SPD status of route A
64	Reserve		Reserved 1
65	Incoming line B		OF+ SD
66			SD
67	Lightning protection B		Determine the SPD status of route B
68	Reserve		Reserved 2
69	Common port		Switch common
70			
81	VSS	Temperature and humidity	Connect WH-3 temperature and humidity sensor
82	DATA		
83	CLK		
84	VDD		

5.2 AMC100-FA30/FA48

AMC100-FA30

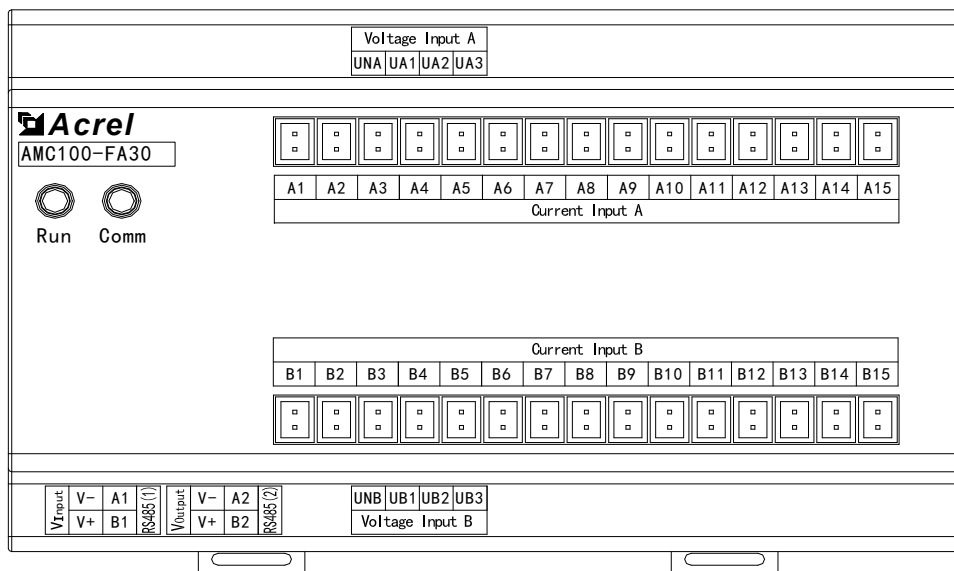

Definition	Illustrate	Remark
V+	Auxiliary power	Powered by AMC100-ZA Or powered by DC12-24V power supply
V-		
A1	RS485(1)	Connect the pre-module
B1		
A2	RS485(2)	Connect the subsequent sub-module
B2		
UNA	Route A voltage input	Three-phase voltage input of circuit A outgoing line
UA1		
UA2		
UA3		
UNB	Route B voltage input	Three-phase voltage input of circuit B outgoing line
UB1		
UB2		
UB3		
A1-A15	Route A current input	circuit A outgoing line AC current input(15 channels)
B1-B15	Route B current input	circuit A outgoing line AC current input(15 channels)

AMC100-FA48

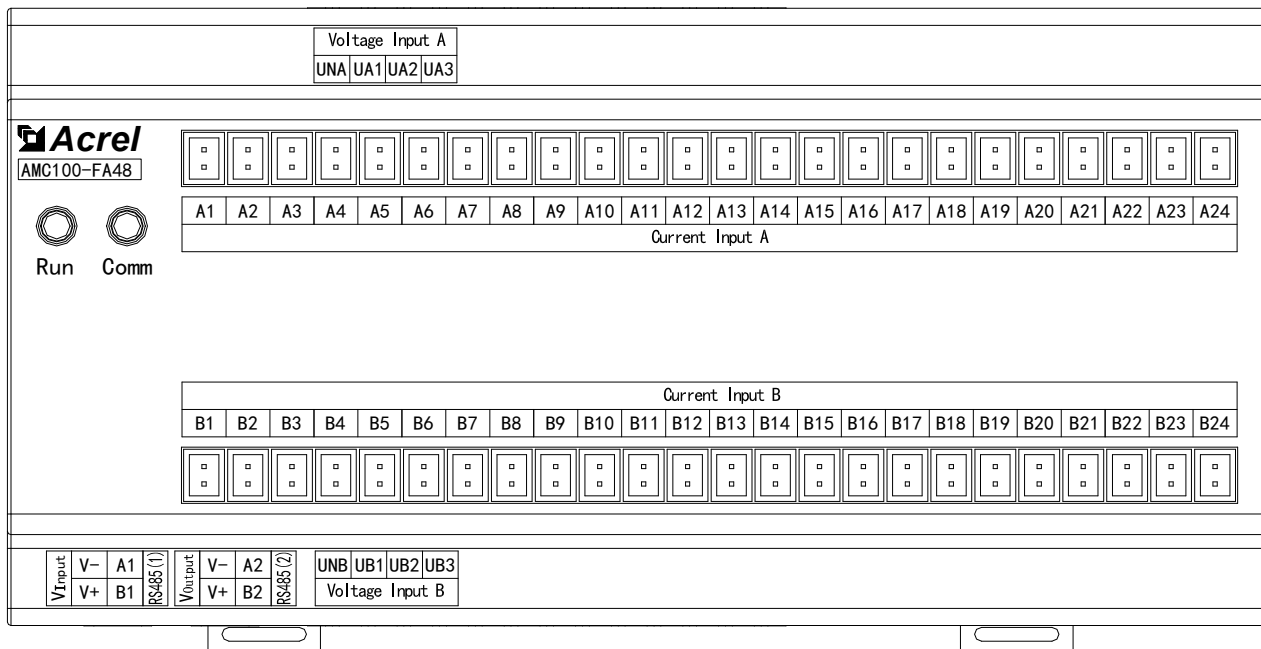

Definition	Illustrate	Remark
V+	Auxiliary power	Powered by AMC100-ZA Or powered by DC12-24V power supply
V-		
A1	RS485(1)	Connect the pre-module
B1		
A2	RS485(2)	Connect the subsequent sub-module
B2		
UA+	Route A voltage input	Three-phase voltage input of circuit A outgoing line
UA-		

UB+	Route B voltage input	Three-phase voltage input of circuit B outgoing line
UB-		
A1-A24	Route A current input	circuit A outgoing line AC current input(24 channels)
B1-B24	Route B current input	circuit A outgoing line AC current input(24 channels)

5.3 AMC100-FAK30/FAK48

AMC100-FAK30

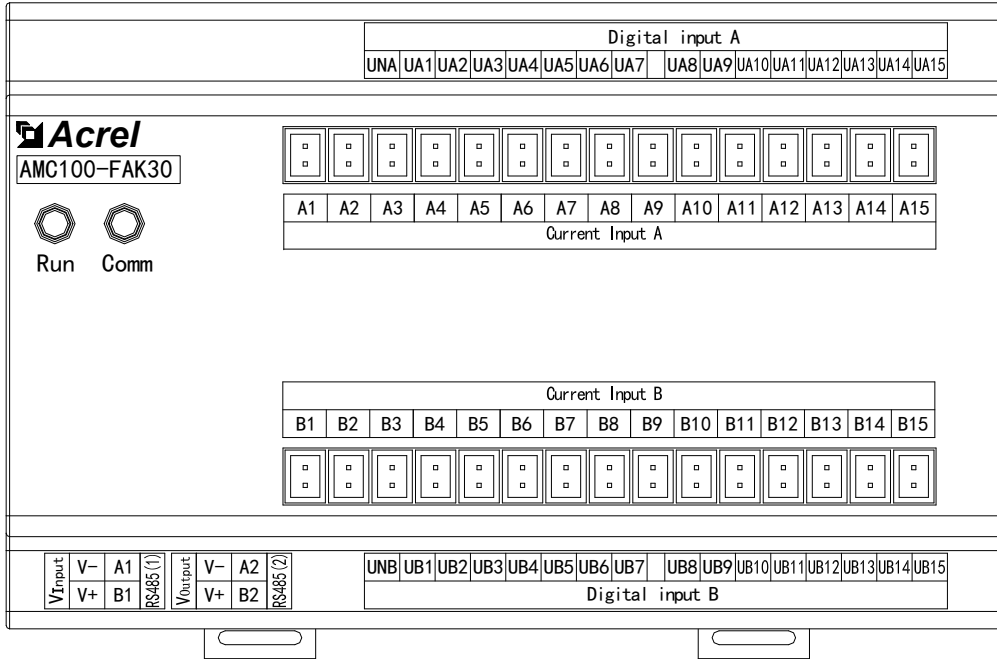

Definition	Illustrate	Remark
V+	Auxiliary power	Powered by AMC100-ZA Or powered by DC12-24V power supply
V-		
A1	RS485 (1)	Connect the pre-module
B1		
A2	RS485(2)	Connect the subsequent sub-module
B2		
UA1-UA15	Route A voltage input	Route A switch input (15 channels)
UNA		
UB1-UB15	Route B voltage input	Route B switch input (15 channels)
UNB		
A1-A15	Route A current input	circuit A outgoing line AC current input(15 channels)
B1-B15	Route B current input	circuit A outgoing line AC current input(15 channels)

AMC100-FAK48

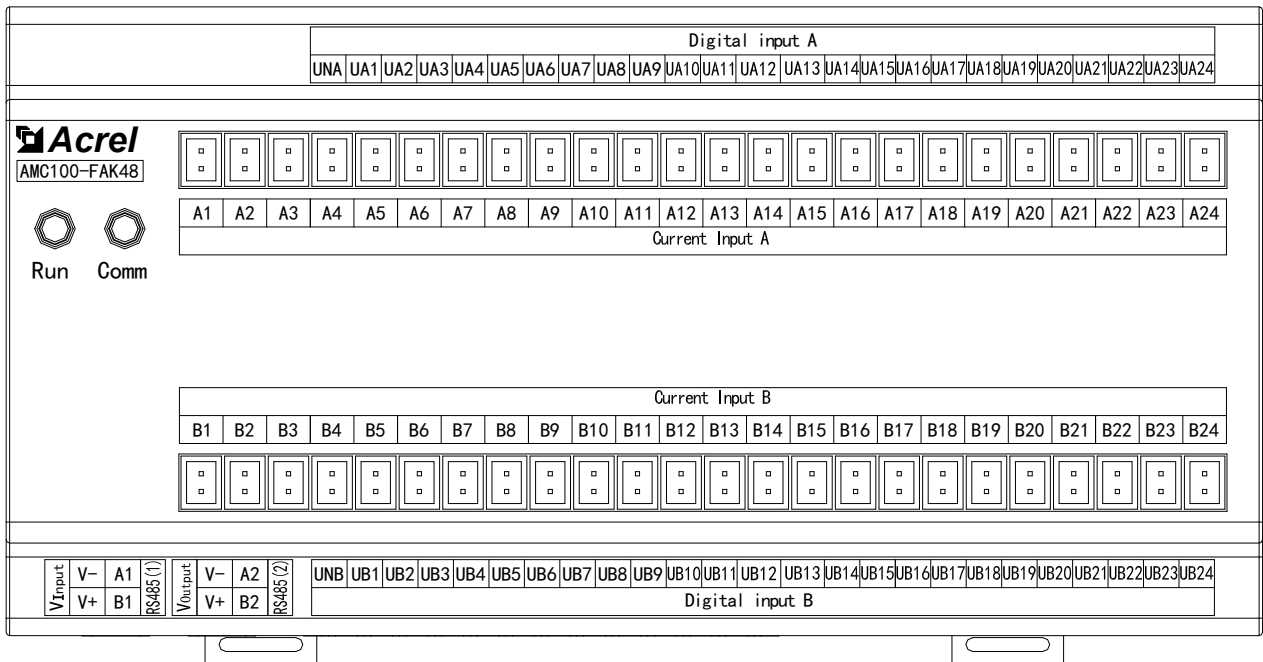

Definition	Illustrate	Remark
V ₊	Auxiliary power	Powered by AMC100-ZA Or powered by DC12-24V power supply
V ₋		
A1	RS485(1)	Connect the pre-module
B1		
A2	RS485(2)	Connect the subsequent sub-module
B2		
UA1-UA24	Route A voltage input	Route A switch input (24 channels)
UNA		
UB1-UB24	Route B voltage input	Route B switch input (24 channels)
UNB		
A1-A24	Route A current input	circuit A outgoing line AC current input(24 channels)
B1-B24	Route B current input	circuit A outgoing line AC current input(24 channels)

5.4 AMC100-KA30/KA48
 AMC100-KA30

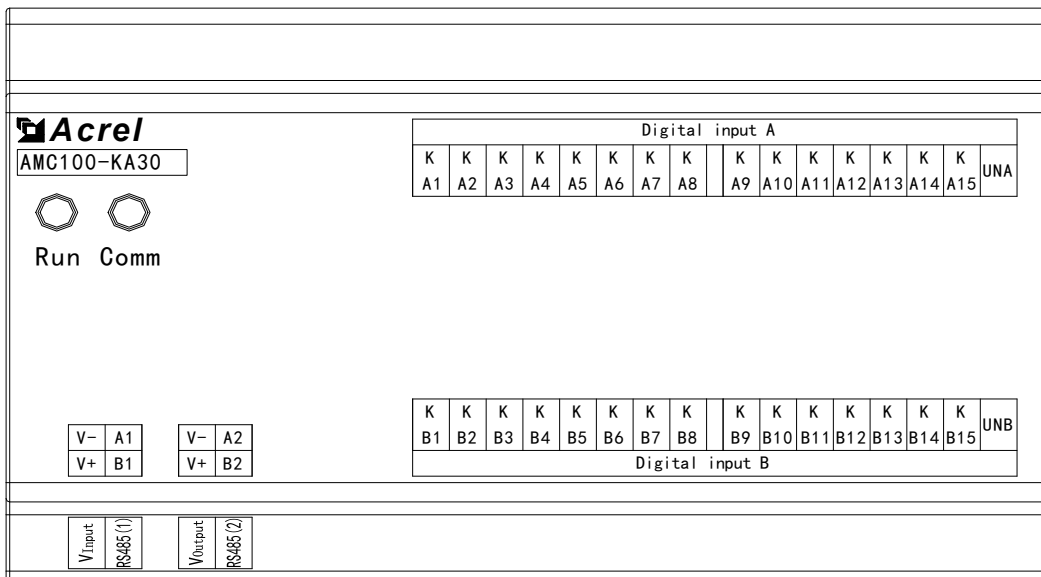

Definition	Description	Remark
V+	Auxiliary supply	Powered by AMC100-ZA Or powered by DC12-24V power supply
V-		
A1	RS485(1)	Connect the pre-module
B1		
A2	RS485(2)	Connect the subsequent sub-module
B2		
KA1-KA15	A channel switch input	A channel active switch input (15 channels)
UNA		
KB1-KB15	B channel switch input	B channel active switch input (15 channels)
UNB		

AMC100-KA48

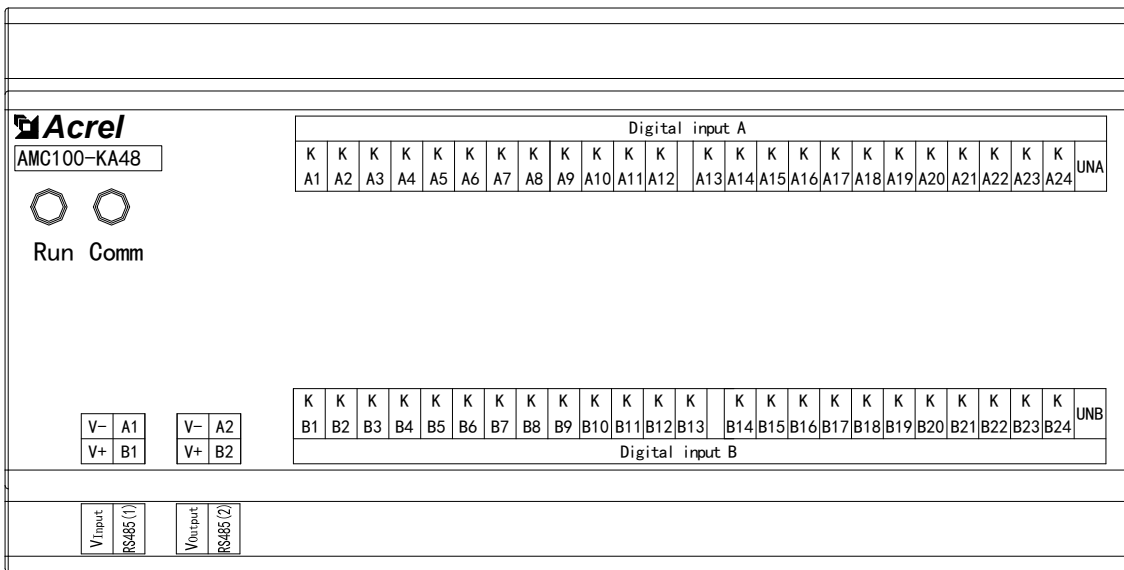

Definition	Description	Remark
V+	Auxiliary supply	Powered by AMC100-ZA Or powered by DC12-24V power supply
V-		
A1	RS485(1)	Connect the pre-module
B1		
A2	RS485(2)	Connect the subsequent sub-module
B2		
KA1-KA24	A channel switch input	A channel active switch input (24 channels)
UNA		
KB1-KB24	B channel switch input	B channel active switch input (24 channels)
UNB		

5.5 AMC100-KD30/KD48
 AMC100-KD30

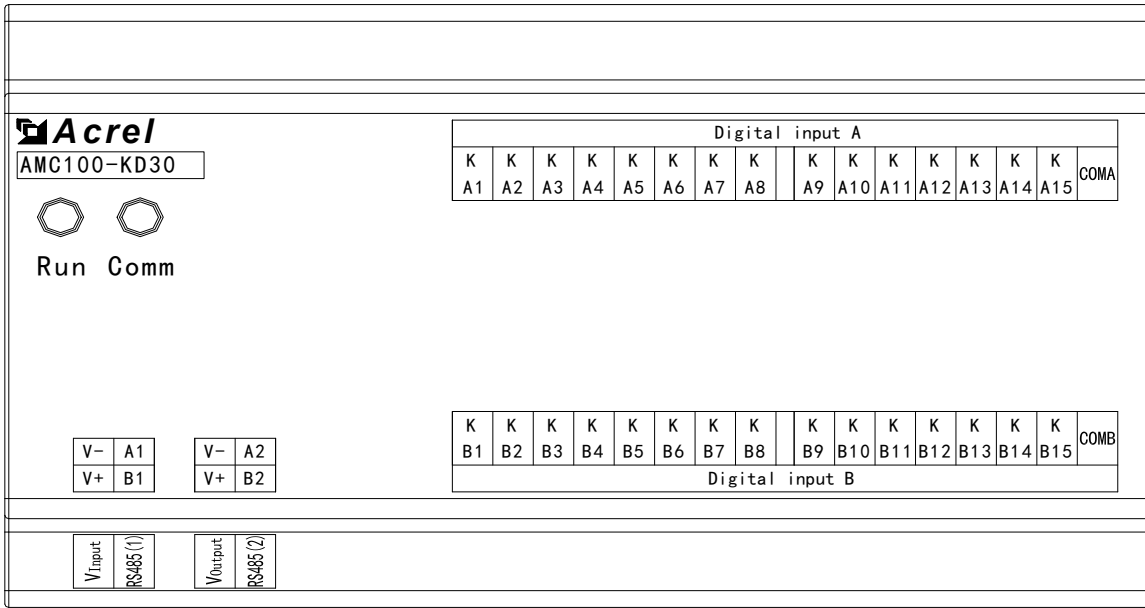

Definition	Description	Remark
V+	Auxiliary supply	Powered by AMC100-ZA Or powered by DC12-24V power supply
V-		
A1	RS485(1)	Connect the pre-module
B1		
A2	RS485(2)	Connect the subsequent sub-module
B2		
KA1-KA15	A channel switch input	A passive switch input (15 channels)
COMA		
KB1-KB15	B channel switch input	B passive switch input (15 channels)
COMB		

AMC100-KD48

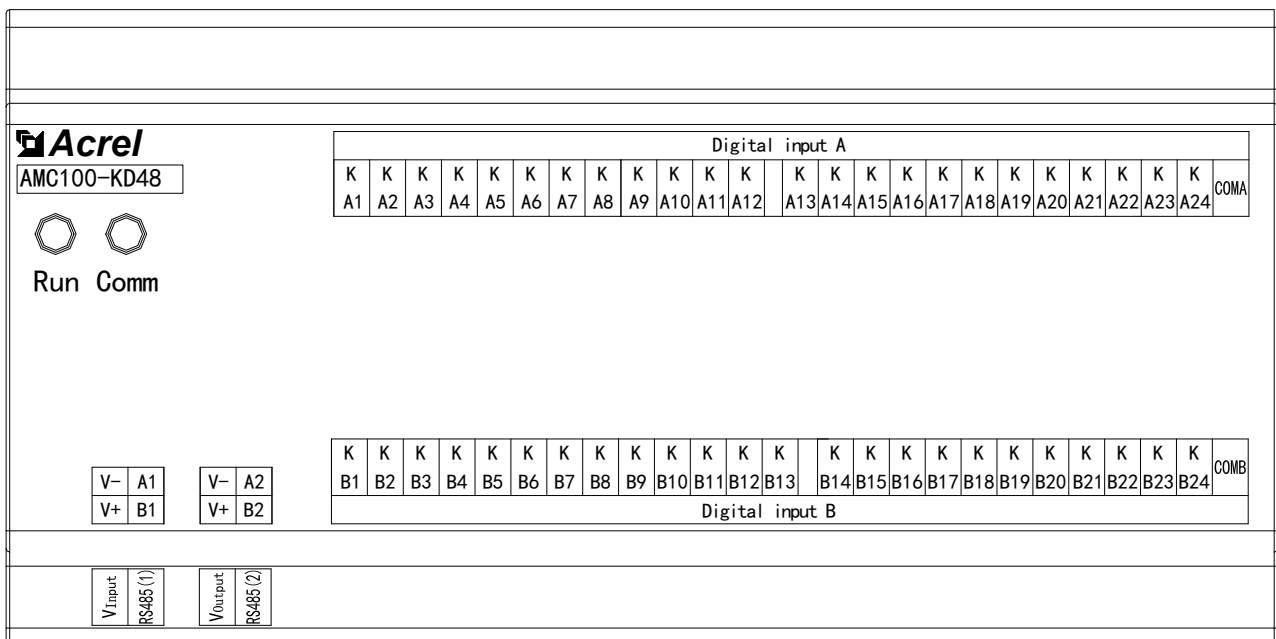

Definition	Description	Remark
V+	Auxiliary supply	Powered by AMC100-ZA Or powered by DC12-24V power supply
V-		
A1	RS485(1)	Connect the pre-module
B1		
A2	RS485(2)	Connect the subsequent sub-module
B2		
KA1-KA24	A channel switch input	A passive switch input (24 channels)
COMA		
KB1-KB24	B channel switch input	B passive switch input (24 channels)
COMB		

5.6 AMC100-FT30/FT48
 AMC100-FT30

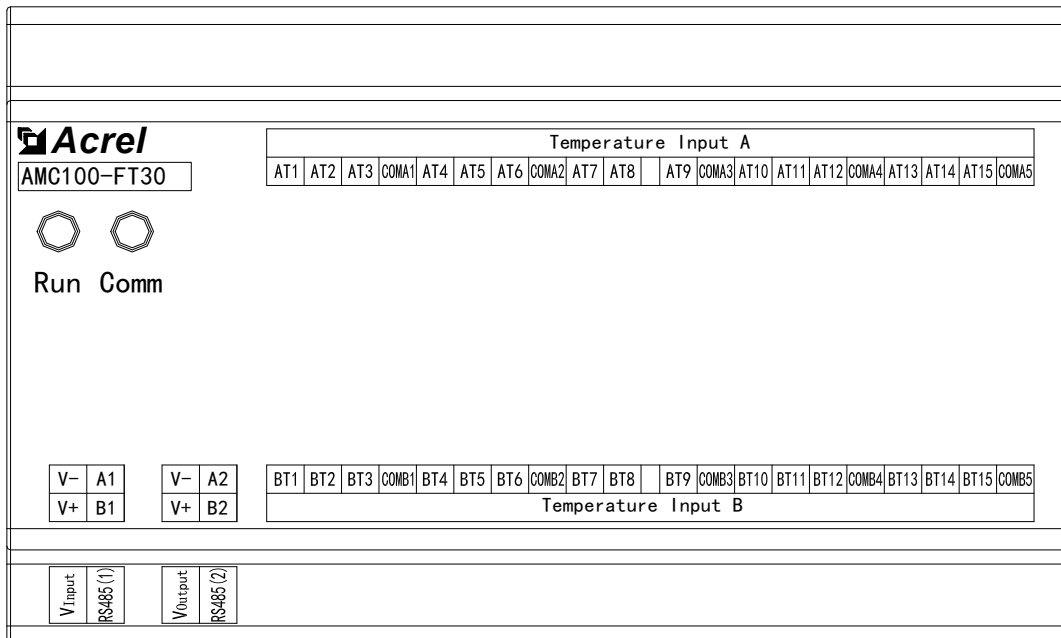

Definition	Description	Remark
V+	Auxiliary power	Powered by AMC100-ZA Or powered by DC12-24V power supply
V-		
A1	RS485(1)	Connect the pre-module
B1		
A2	RS485(2)	Connect the subsequent sub-module
B2		
AT1-AT15	A channel temperature input	A temperature input(15 channels)
BT1-BT15	B channel temperature input	A temperature input(15 channels)

AMC100-FT48

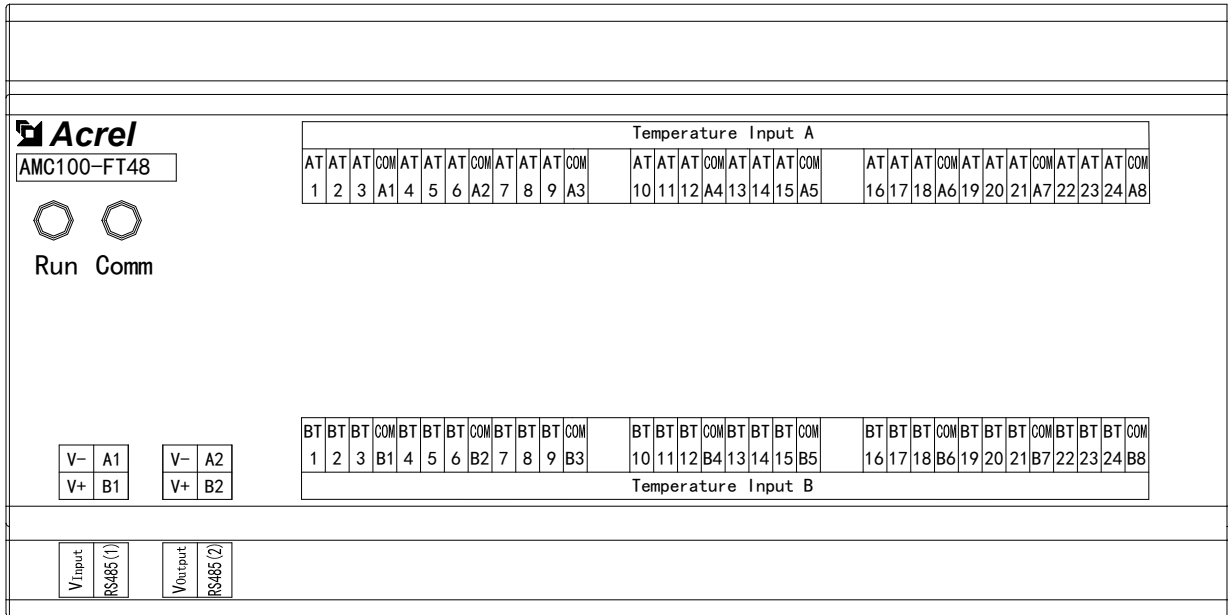

Definition	State	Remark
V ₊	Auxiliary supply	Powered by AMC100-ZA Or powered by DC12-24V power supply
V ₋		
A1	RS485(1)	Connect the pre-module
B1		
A2	RS485(2)	Connect the subsequent sub-module
B2		
AT1-AT24	A temperature input	A temperature input(24channels)
BT1-BT24	B temperature input	A temperature input(24 channels)

5.7 Typical primary wiring diagram

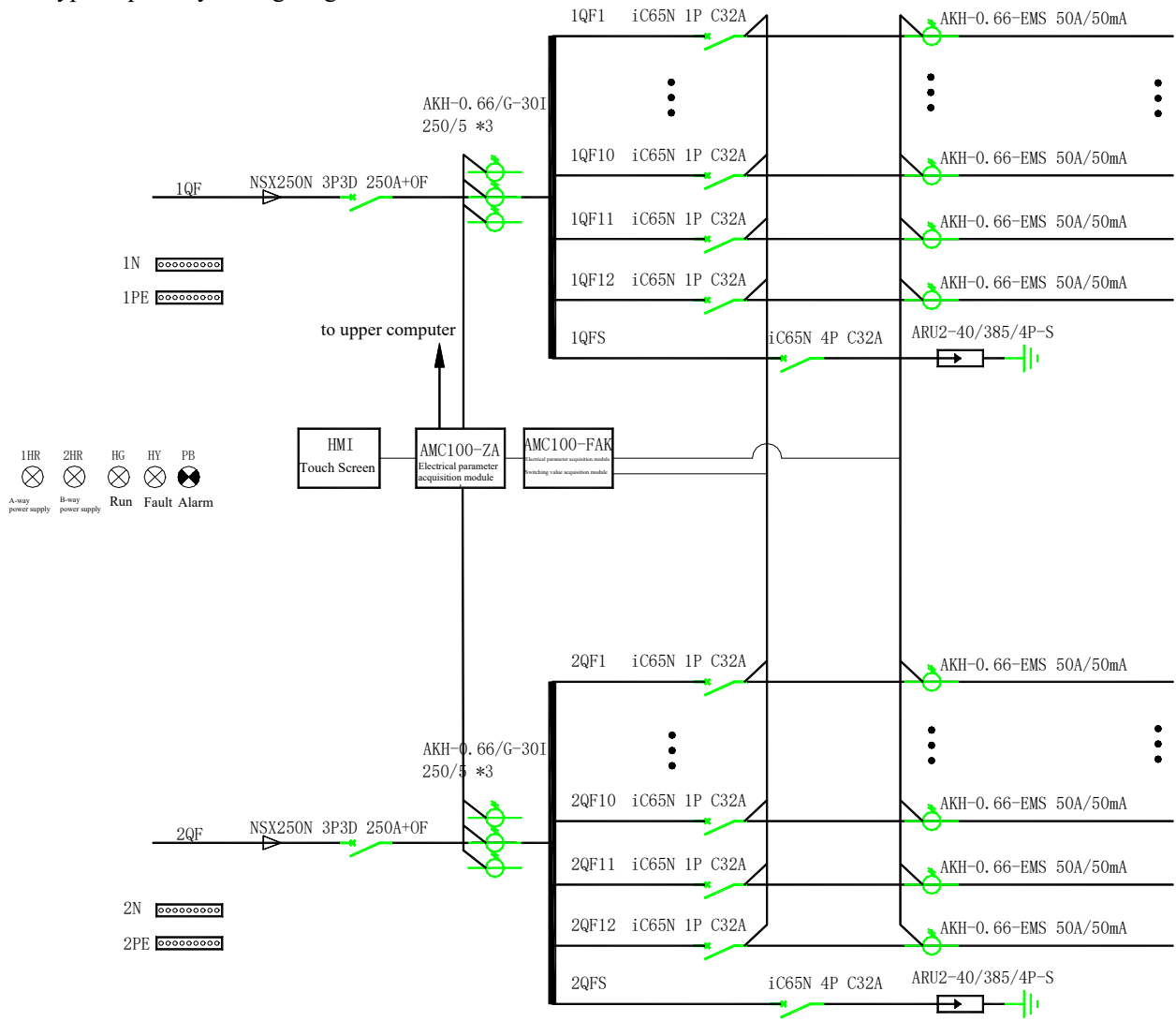

6 Touch Screen

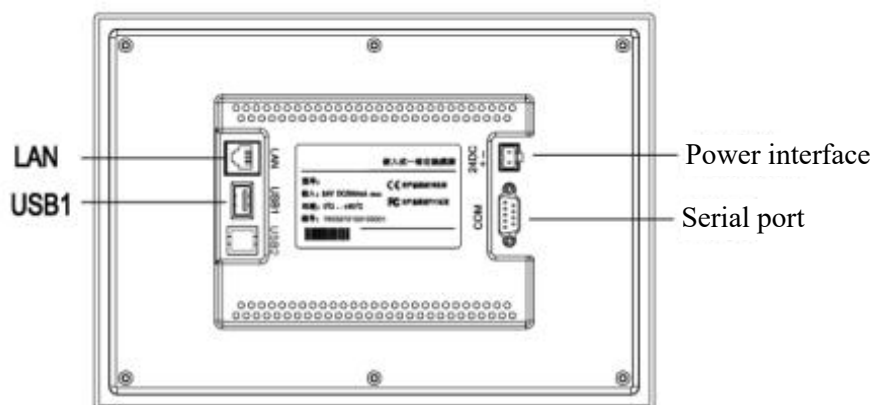

Serial port(DB9)	2×RS485
USB1	Main port,compatible with USB2.0 standards
LAN (RJ45)	Ethernet interface
Power interface	24V DC ±20%

Serial port (DB9) pin definition

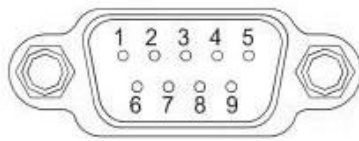

Serial port pin definition

Interface	PIN	Pin definition
COM1	2	RS232 RXD
	3	RS232 TXD
	5	GND
COM2	7	RS485 +
	8	RS485 -
COM3	4	RS485 +
	9	RS485 -

6.1 Appearance and installation

7-inch touch screen appearance and installation (ATP007KT)

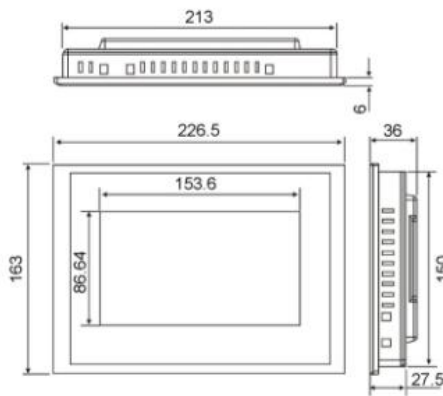

Dimension

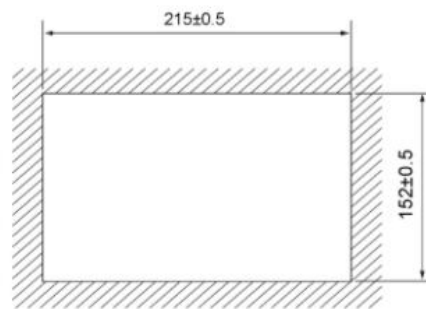

Hole Size

7-inch touch screen appearance and installation (ATP007W)

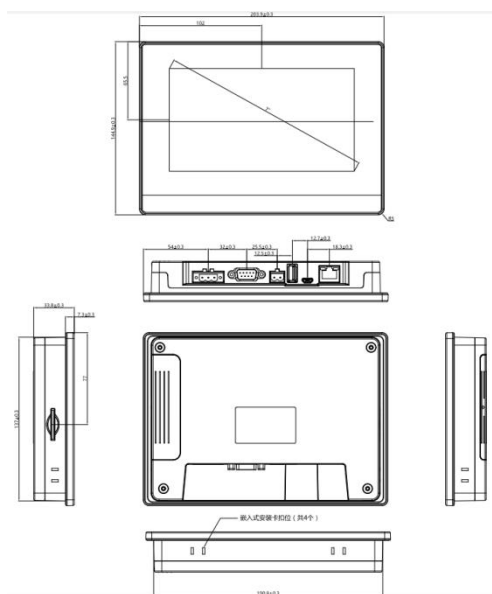

Dimension

Hole Size

10-inch touch screen appearance and installation (ATP010KT)

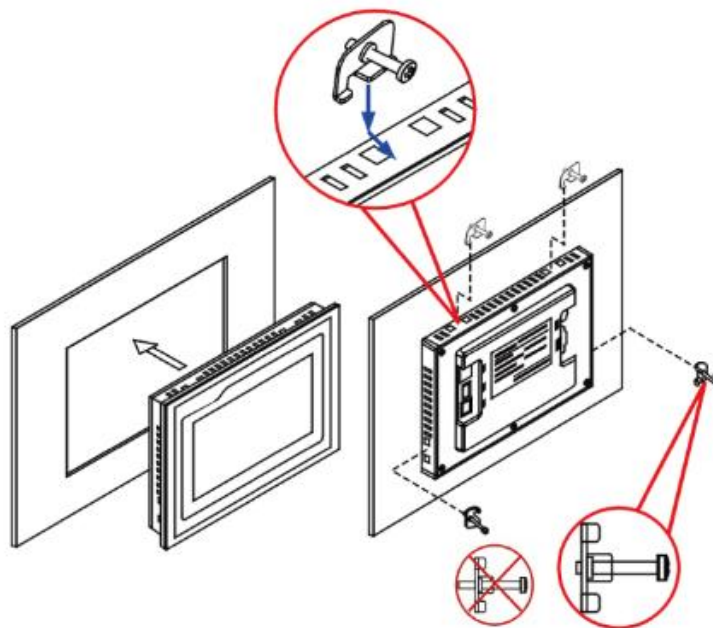
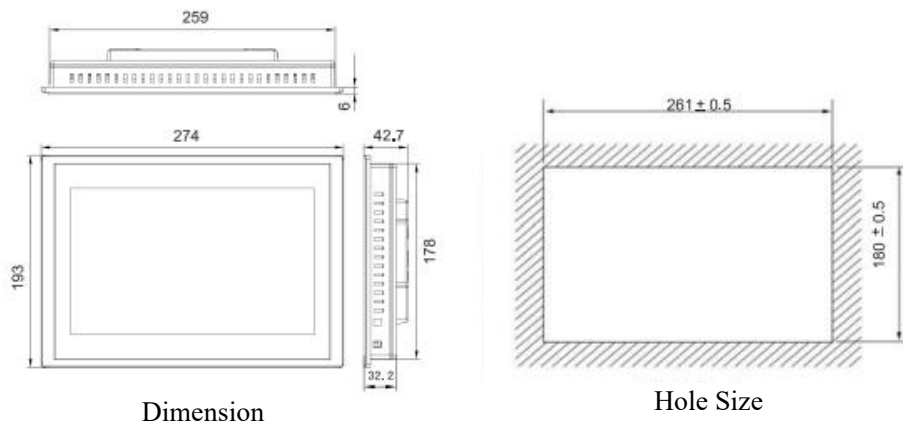

6.2 Wiring power wiring

- Step1:Strip the 24V power cord and insert it into the wiring terminal of the power plug.
- Step2:Use a flat screwdriver to lock the power plug screw tightly.
- Step3:Insert the power plug into the product’s power outlet.
- Tip:Use a power cord with a diameter of 1.25mm² (AWG18).

The schematic diagram and pin definition of the power plug are as follows

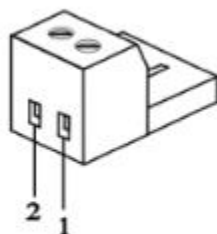

PIN	Definition
1	+
2	-

Only 24VDC, recommended for independent power supply, with an output power of 15W.

Communication wiring

The factory configuration has a green adapter board, of which (7-8) is downlink (7 docking 485A; 8 docking 485B), connected to 485 of the module, green and white (4-9) uplink (4 docking 485A; 9 docking 485B), to rotate the ring.

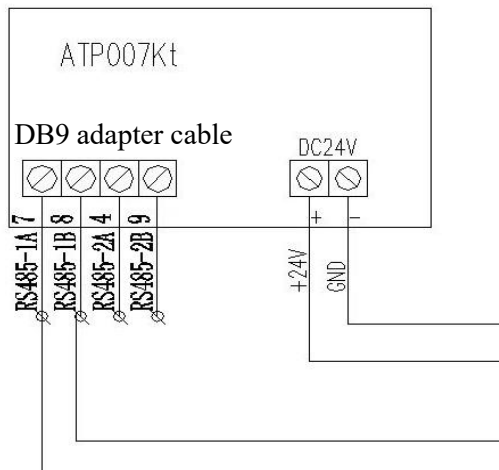
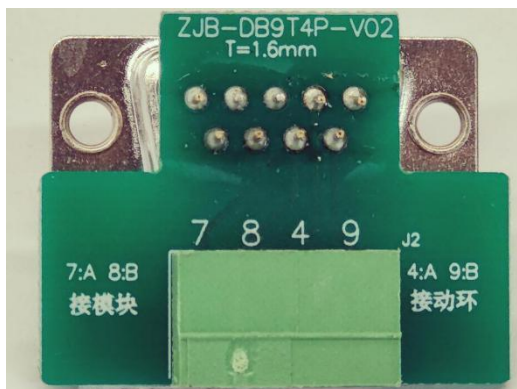

Note: The following describes system interface 1 and interface 2. Interface 2 is an upgraded version based on interface 1, and it will take effect from September 2022.

7 Details of parameters, functions, and operations



As shown in the picture, the first interface after the touch screen turned on is the home page, the home page is unique. And all functions can be accessed by finding the corresponding buttons on the home page. The parameters in the homepage are taken from the first incoming line.

7.1 Incoming Line Parameters

Click "Incoming Line Parameters" on the home page to view incoming line/main circuit parameters. The main parameters are as follows:

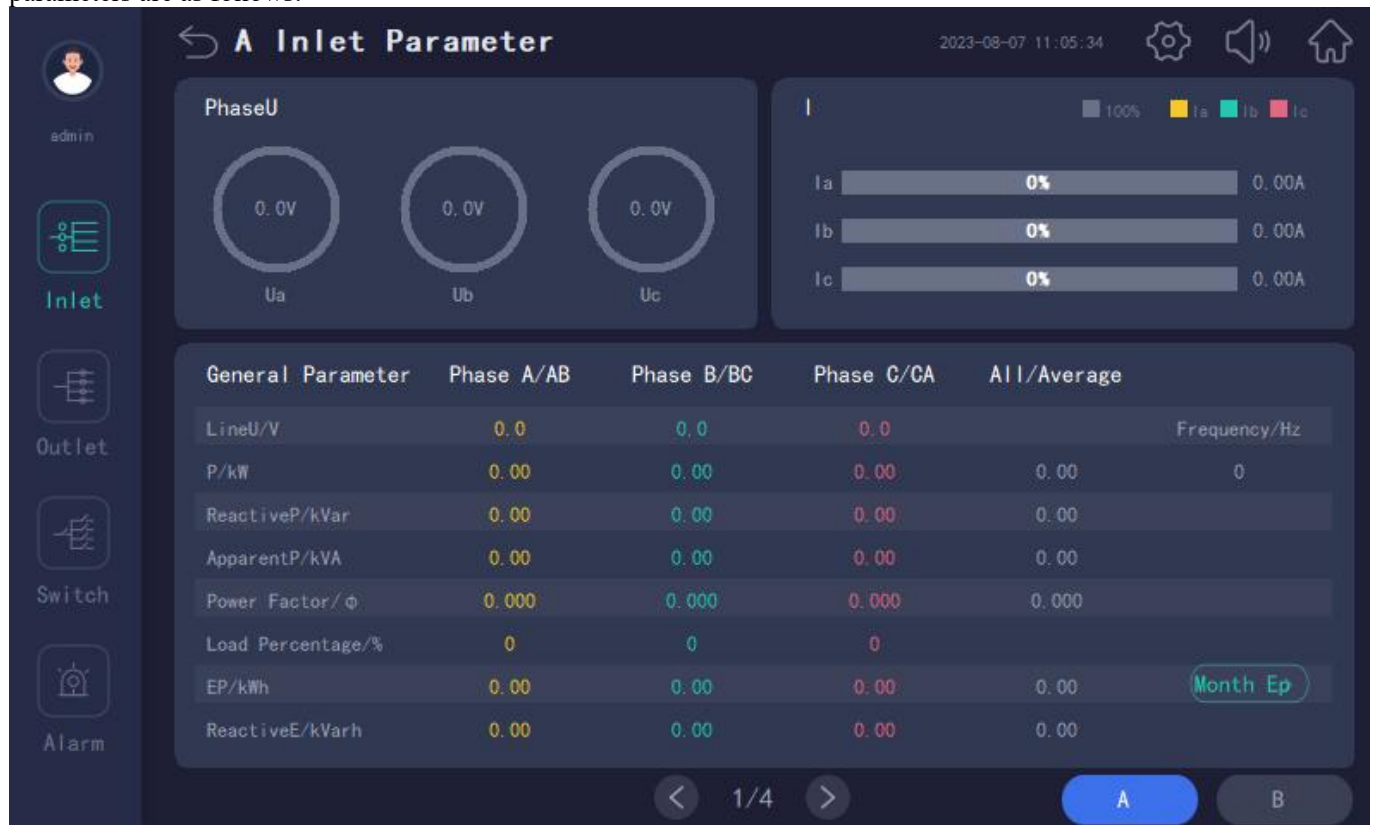

The main parameters :voltage of different phases, current, line voltage, active power, reactive power, apparent power, power factor, load percentage, active energy, reactive energy and frequency of each phase.

The monthly electric energy is the cumulative electricity consumption of each month, and the monthly electric energy data is recorded once at the beginning of each month and displayed in the table. Click the switch button below to switch to view the monthly power of the incoming line and the monthly power of each outgoing line.

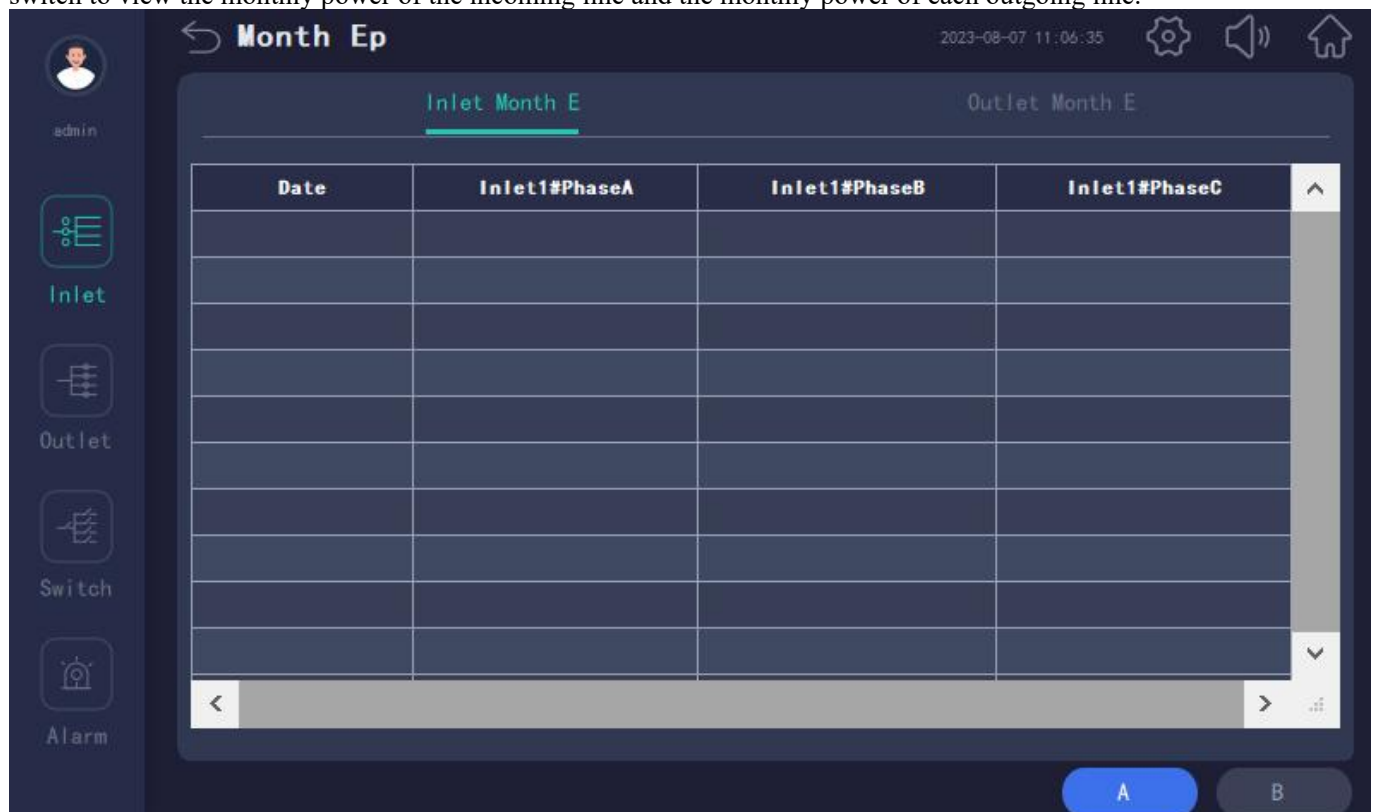

Click the upper left corner to return to the incoming line parameter interface.
 If you have more parameters to view, please click the page turning button below.



The parameters on page 2 include zero-sequence current, zero-ground voltage, leakage current, voltage unbalance, current unbalance, cabinet temperature, and cabinet humidity.



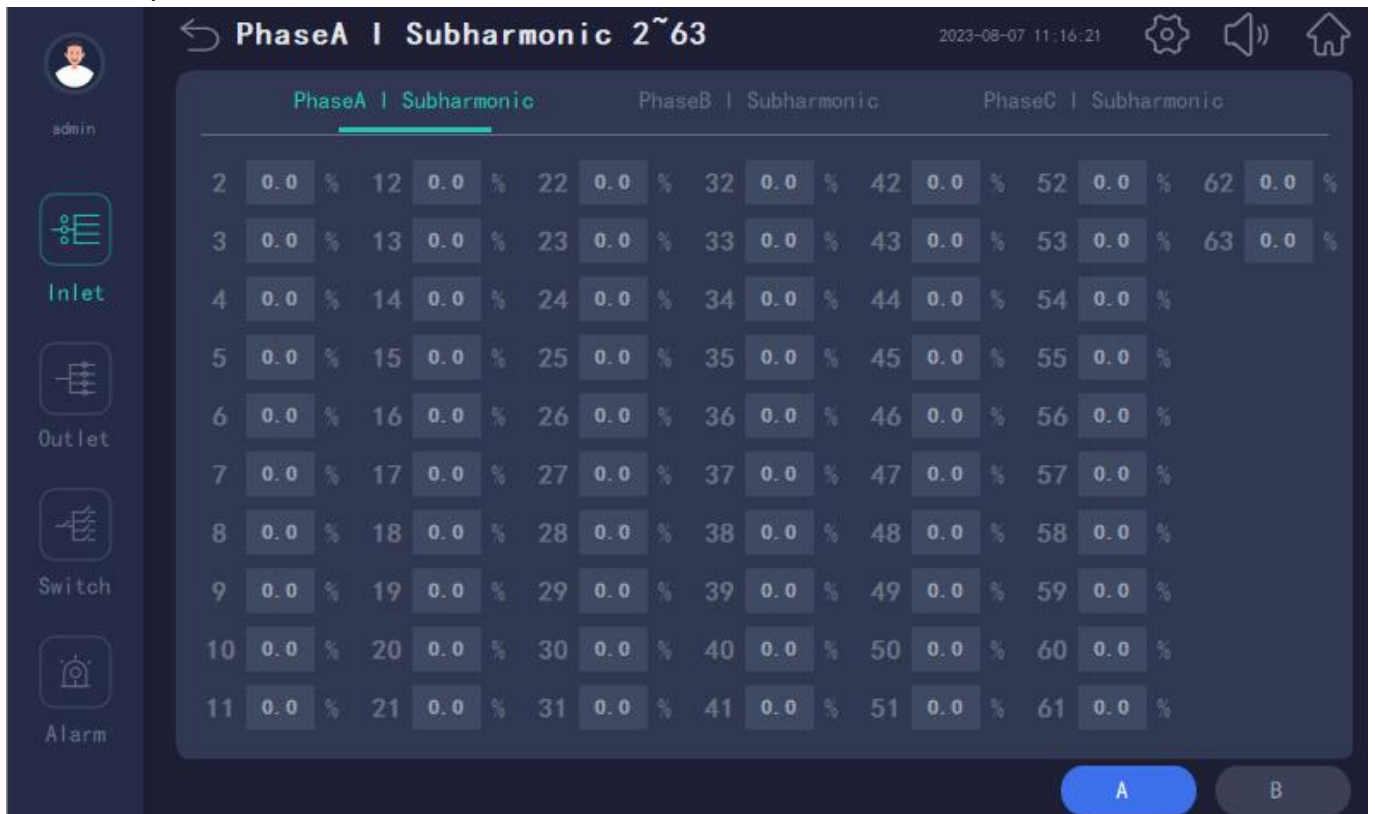

The third page is harmonic related parameters. You can view the fundamental active power, harmonic active power, fundamental active energy, and voltage total harmonics of each phase. Click the corresponding arrow to view the 2~63rd current subharmonic and voltage subharmonic of each phase.

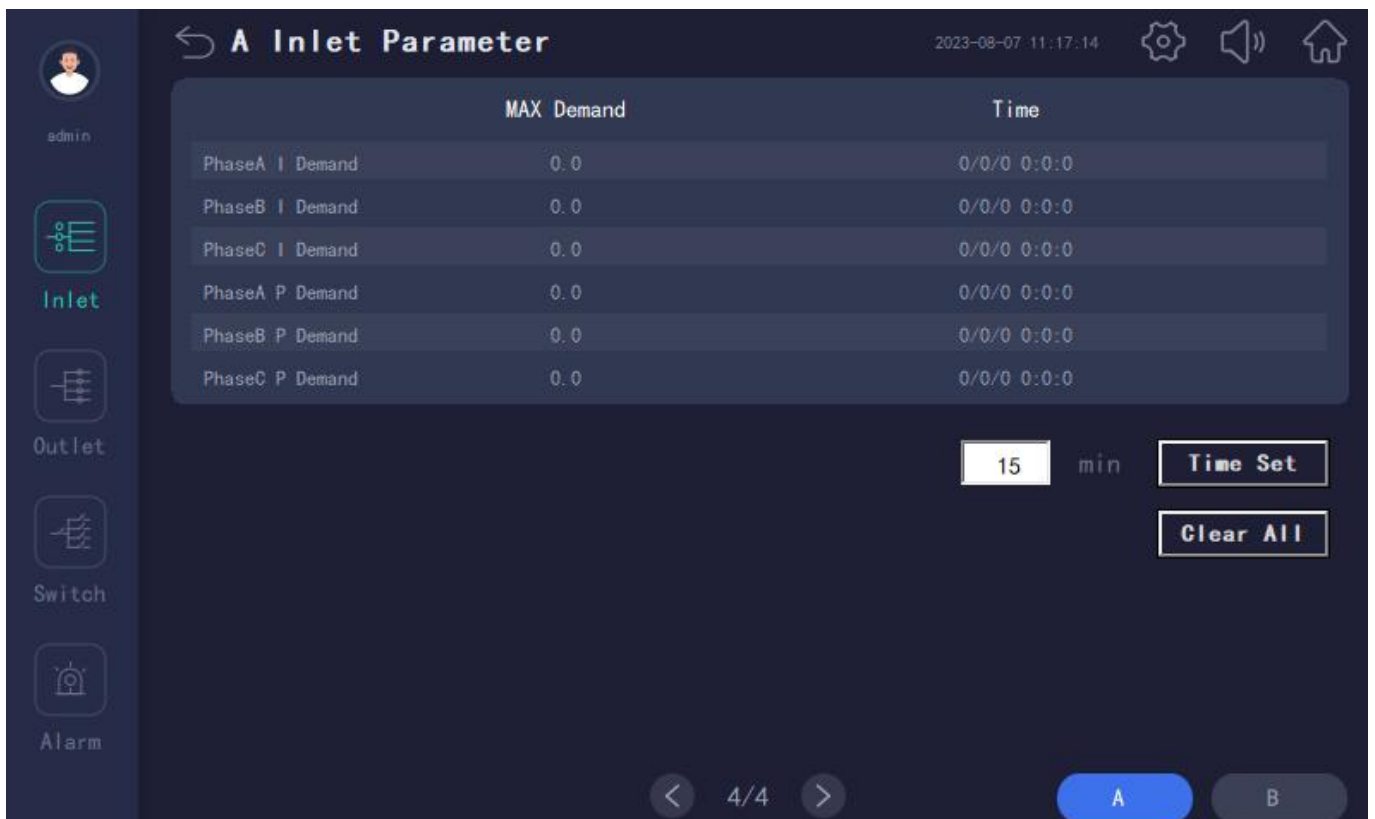

Page 4 is the maximum demand for incoming line current and power. The maximum demand is the maximum value of the average value generated by the current and power history of the incoming line during the set time. Click the back button in the upper left corner to return to the home page.

7.2 Outgoing parameters

On the home page, click "Outgoing Parameters" to enter or click on the Outgoing Parameter icon in any parameter viewing interface to enter.

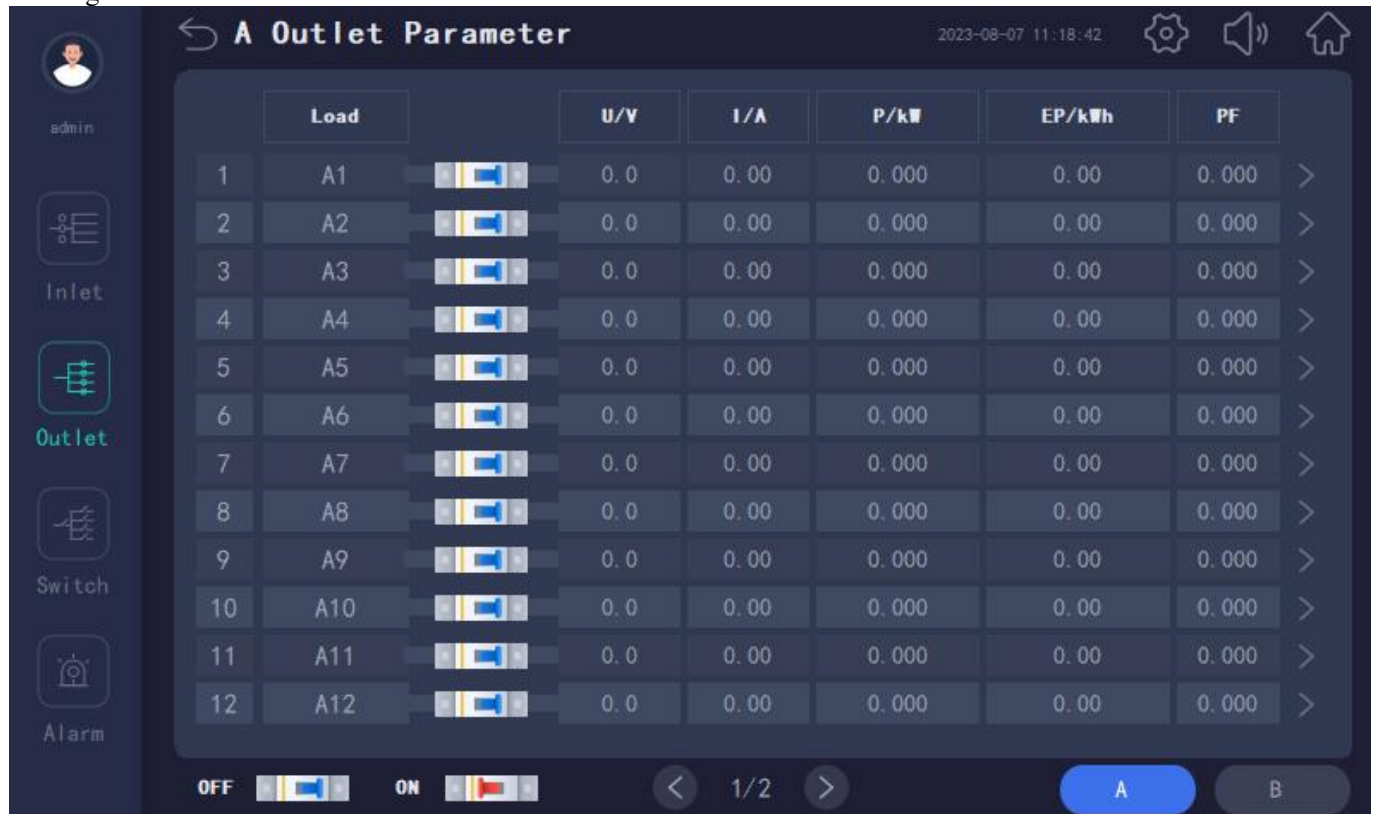

Outgoing parameters mainly include voltage, current, active power, active energy, and power factor.

If you need other parameter information, click the small arrow on the right to view the specific parameters of the road.



After clicking to close the window, you can view other circuit information.

The name of the circuit can be modified. For the modification method, see Modifying name of the circuit below.

7.3 Switch state

Click "Switch Status" on the home page to enter or click on the Switch Status icon in any parameter viewing interface to enter.

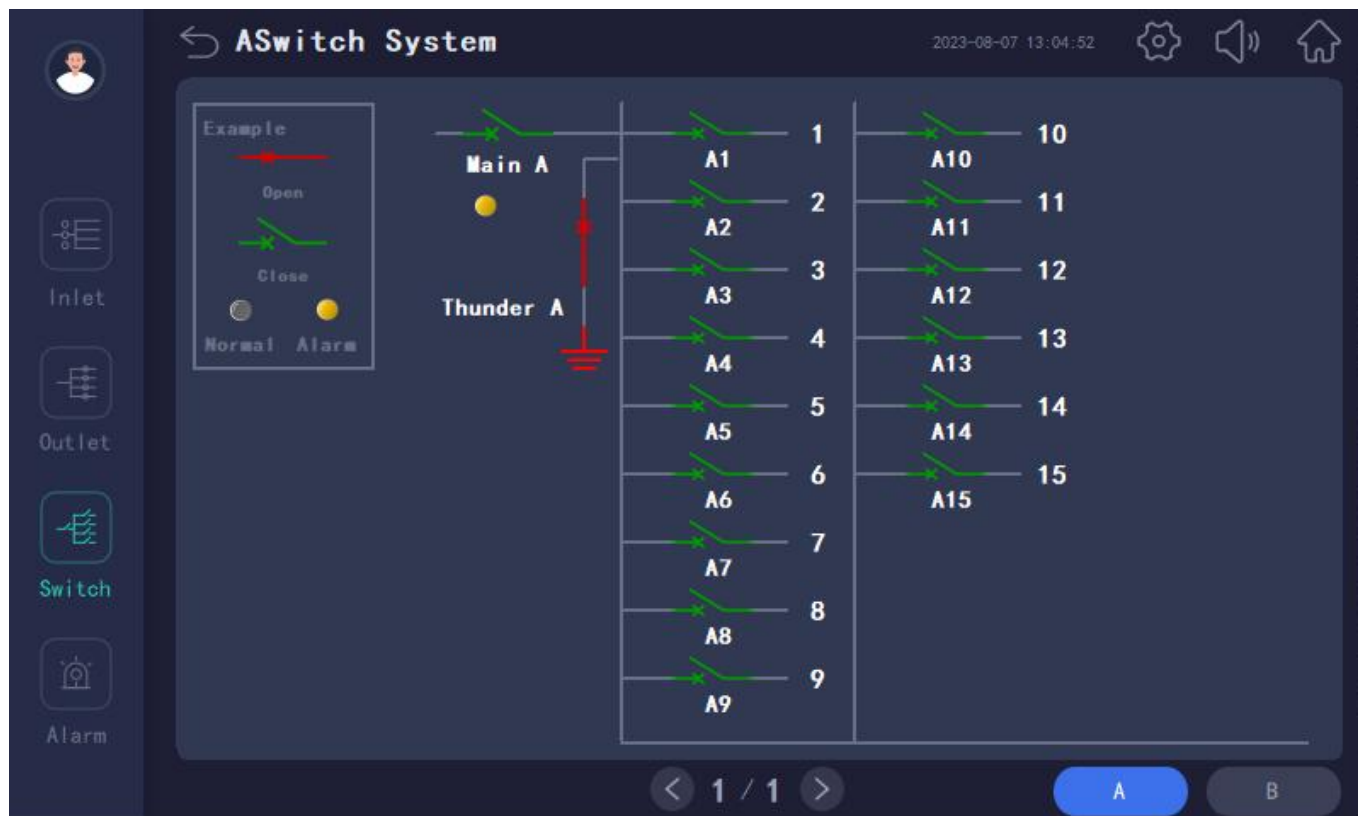

7.3.1 Main switch state

7.3.1.1 The leftmost column defaults to the main road switch status, main road trip SD status, main road lightning protection switch status, and main road lightning protection fault point status. The default is passive detection point. Open is red and closed is green.

7.3.1.2 The switch state of the main circuit can be set and modified to active detection mode.

7.3.1.3 The name can be modified for detection of other switching points.

7.3.1.4 You can set normally open and normally closed to modify the alarm logic.

7.3.1.5 If there is no such detection requirement, it can be set to hide.

Refer to the following "Alarm Settings" for the above setting methods.

If the user finds that the switch state is inconsistent with the actual situation during actual use, it is necessary to check the active and passive selection and normally open and normally closed selection in the "alarm settings".

It should be noted that if the number of circuits exceeds 2, the default wiring method is to connect incoming wires 1 and 2 to the first AMC100-ZA, and incoming wires 3 and 4 to the second AMC100-ZA. The default display method is that incoming lines 1 and 3 are on the same interface, sharing one outgoing line, while incoming lines 2 and 4 are on the same interface, sharing one outgoing line.

7.3.2 Branch switch state

The right side of the switch state of the main circuit is the switch state of the branch circuit, and the default is the active detection point. The Open one is red and the closed one is green.

The name of the switch can be modified. For the modification method, see Modifying the circuit name below.

It can be modified to passive detection mode. For setting, refer to "Alarm Setting" below.

7.4 Alarm query

7.4.1 Current alarms

Click "Alarm Query" on the home page or click on the Alarm Query icon in any parameter viewing interface to enter to view the current alarm.

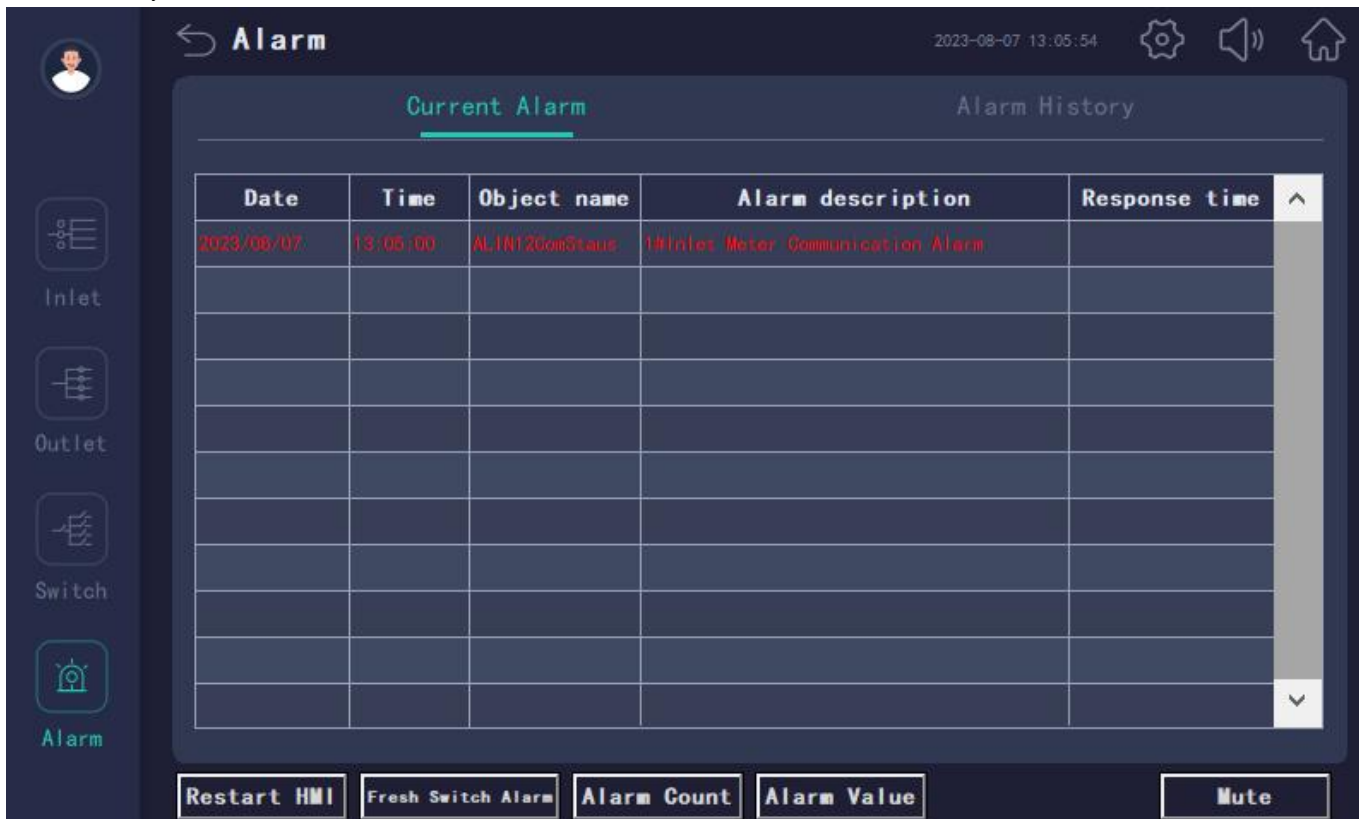

When an alarm occurs, the relay output of the buzzer and indicator light will act, and the screen will beep at the same time. The buzzer and buzzer relay output can be eliminated by clicking the Acknowledge Alarm button.

To solve the current alarm, it is necessary to clarify the content of the current alarm, and the alarm description shall prevail. When there is a communication failure, the communication failure shall be solved first, and then the corresponding problem shall be found according to the alarm description.

When the current alarms are all restored, the relay output of the buzzer and the indicator light will automatically restore.

7.4.2 History alarm

Click "Historical Alarm" on the current alarm page to view historical alarms.

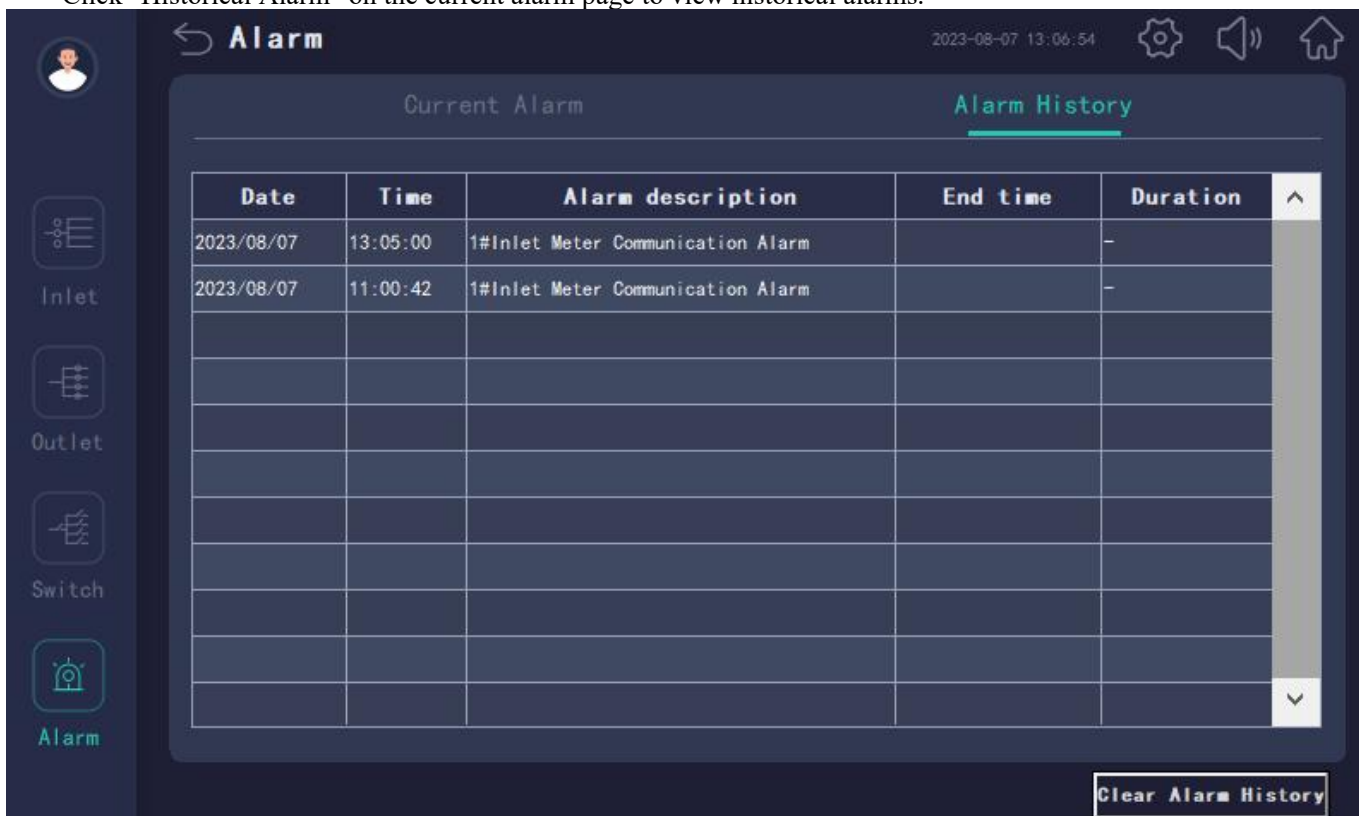

Click "Clear Historical Alarms" to clear historical alarms. This button requires user login on the home page to obtain permission.

7.4.3 Alarm Count

If there is a need for alarm counting, you can click on the alarm counting button in the current alarm interface to view it.

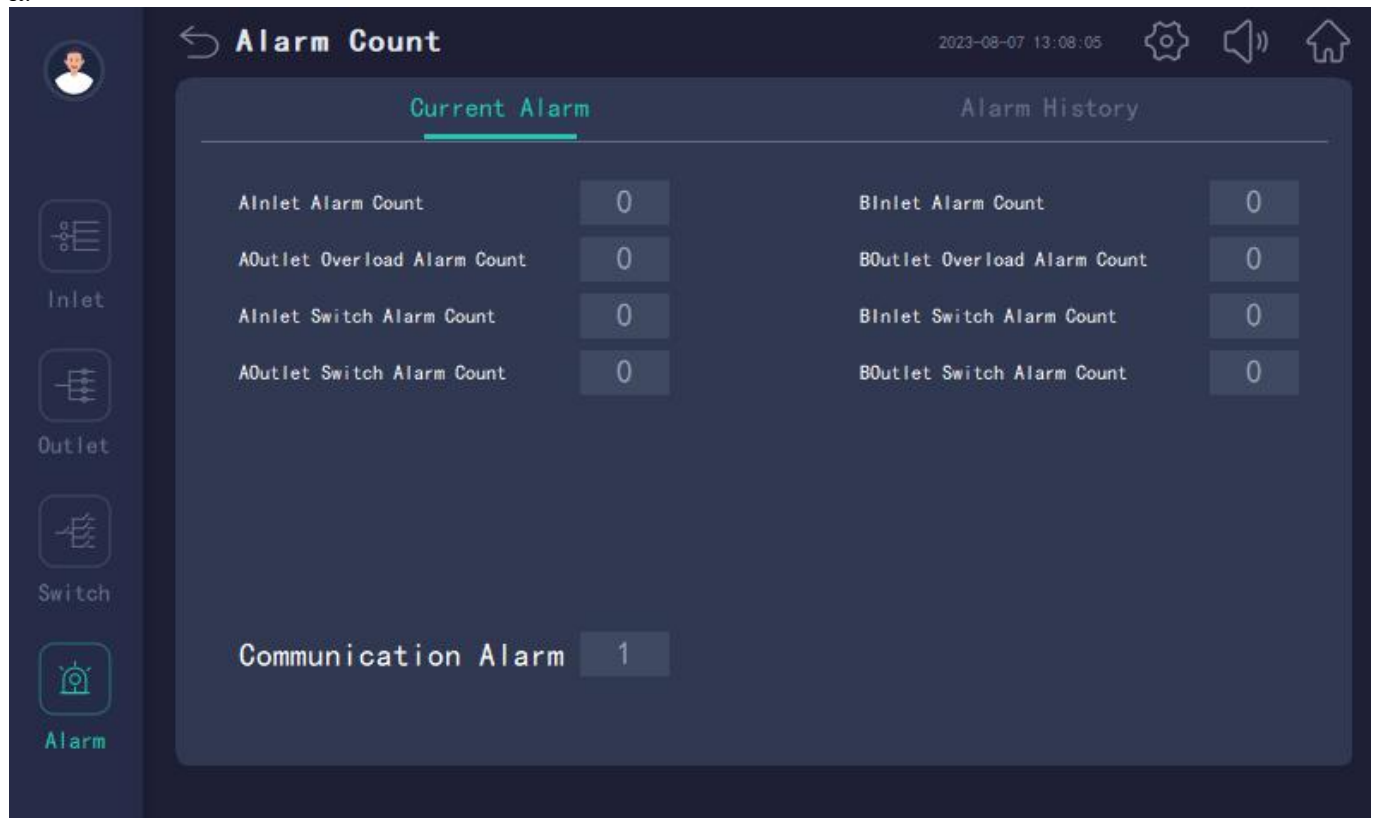

7.4.4 Alarm Value Query

Click on the alarm value query in the current alarm interface, and when an incoming and outgoing line overload alarm occurs, the specific current value corresponding to the alarm generation will be displayed.

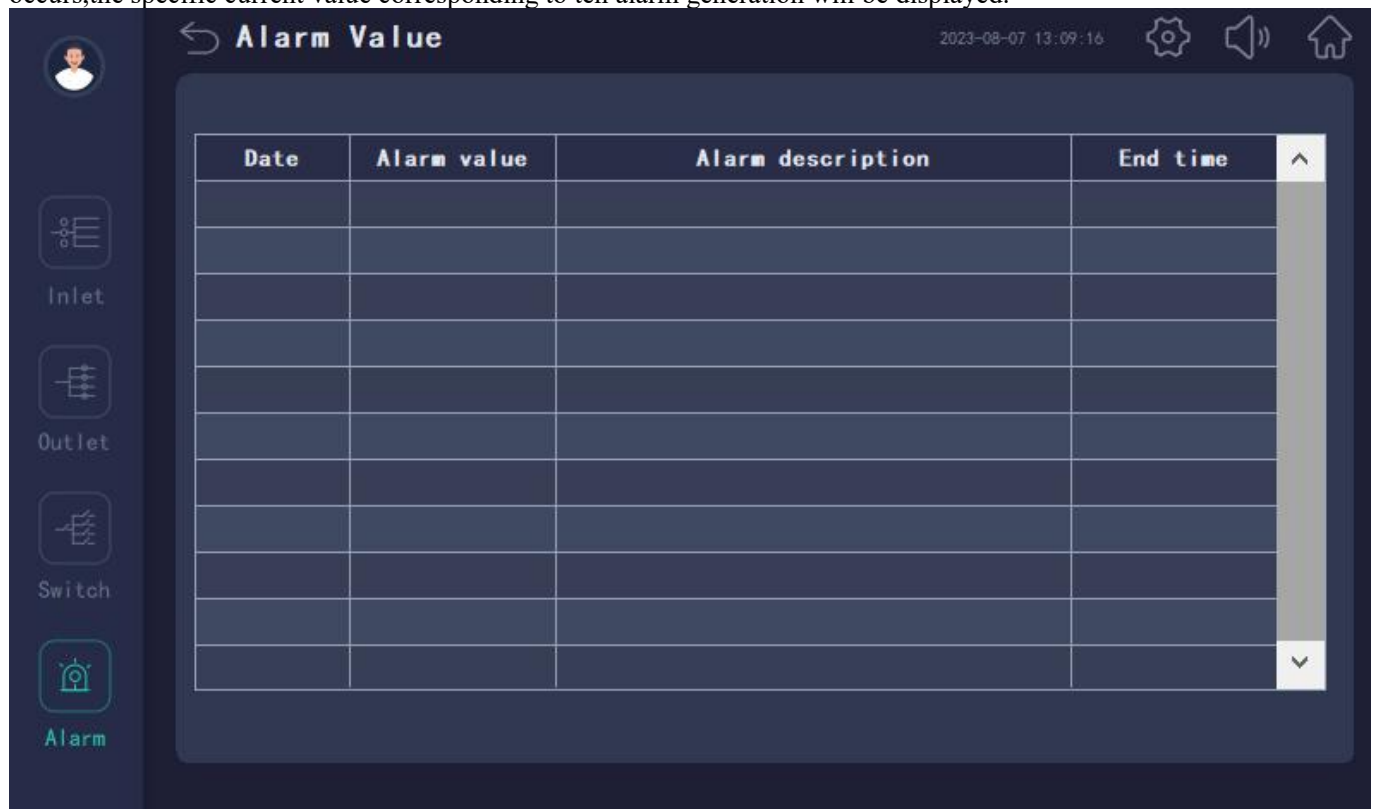

7.5 User login

After the user logs in, the setting operation can be performed.

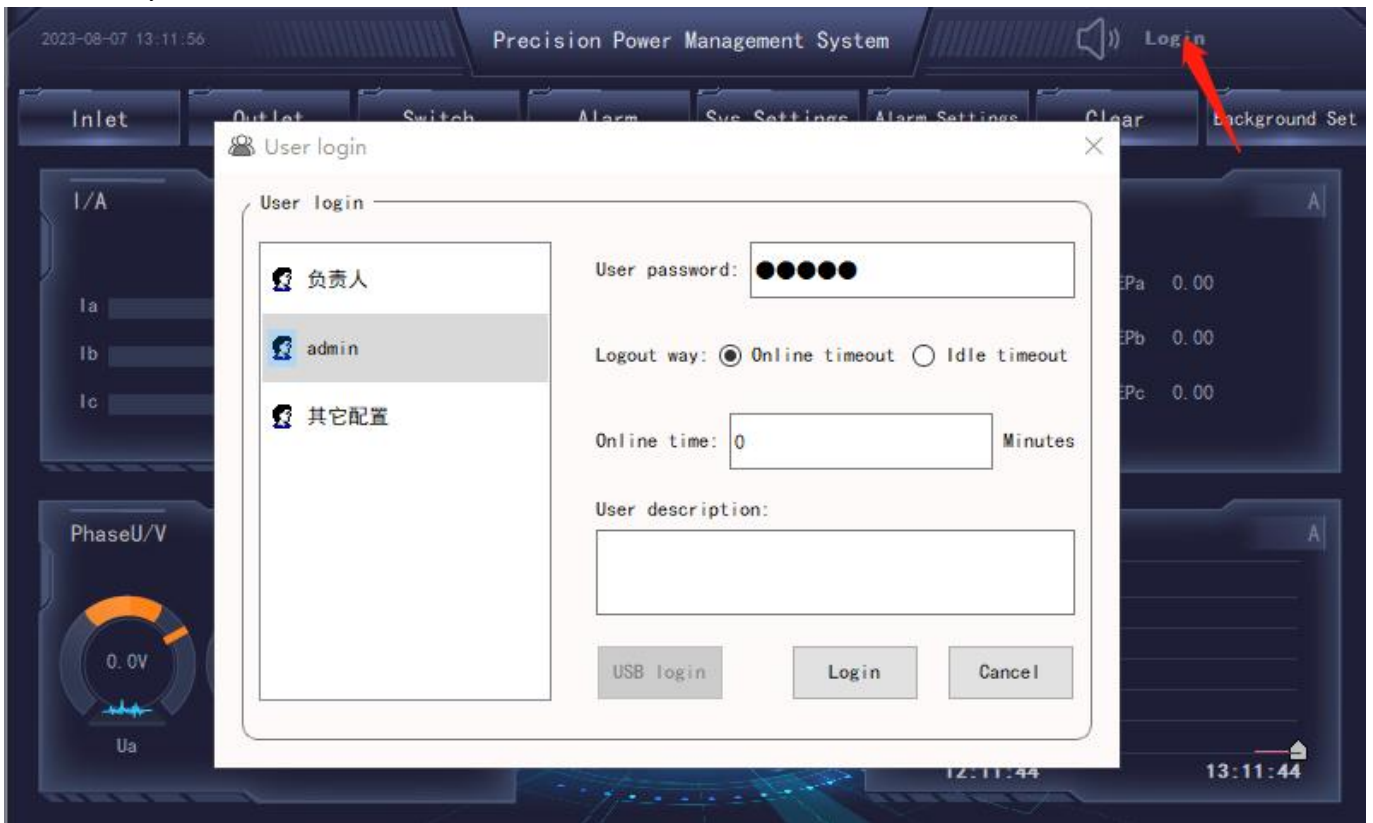

password of the person in charge : 123
Admin password: 10000

7.6 Time setting

Refers to the time setting of the touch screen. After logging in as a user, click the time to enter the time modification interface.

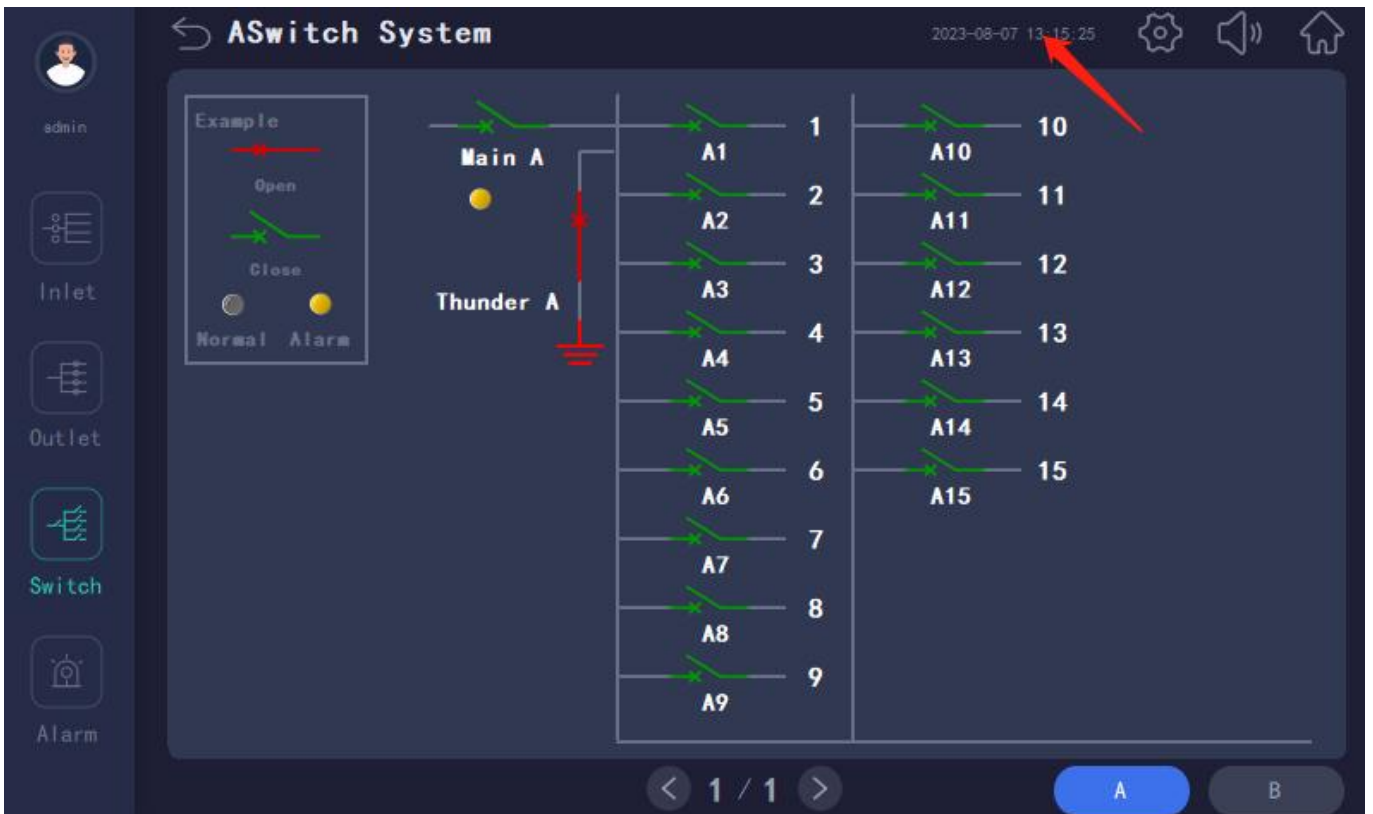

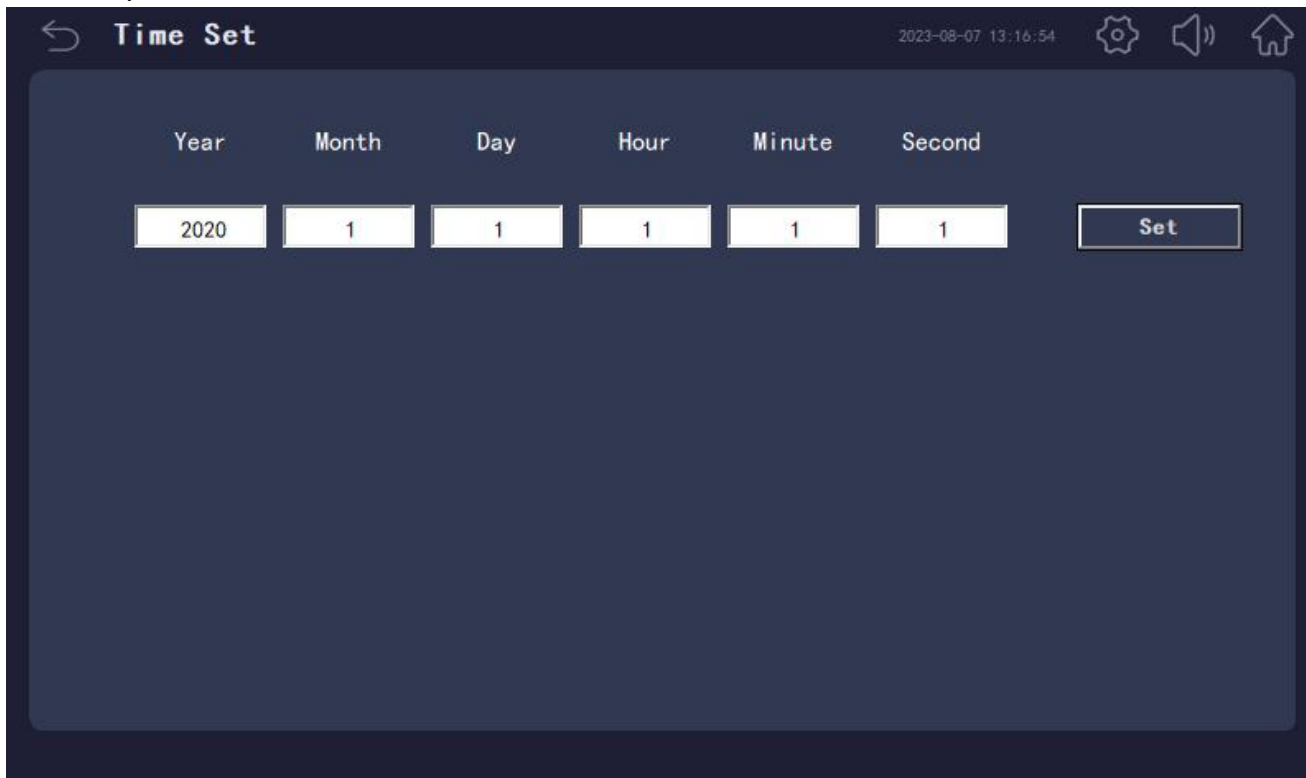

7.7 System Settings

Click "System Settings" on the home page to enter the settings.

The system settings are personalized for each system, that is, according to the number of loops and parameters of each application scenario, the settings are made to match the current system.

System settings include outgoing line mode, number of circuits, number of switching circuits, incoming line switch load rating, incoming line CT ratio, outgoing line switch load rating, outgoing line CT transformation ratio, and name setting for each outgoing line circuit.

Any changes to this section must be done by clicking the "Save Settings" button.

7.7.1 Number of loops Setting

After clicking to enter "System Settings", set the type of incoming and outgoing lines and the number of circuits in the first interface.

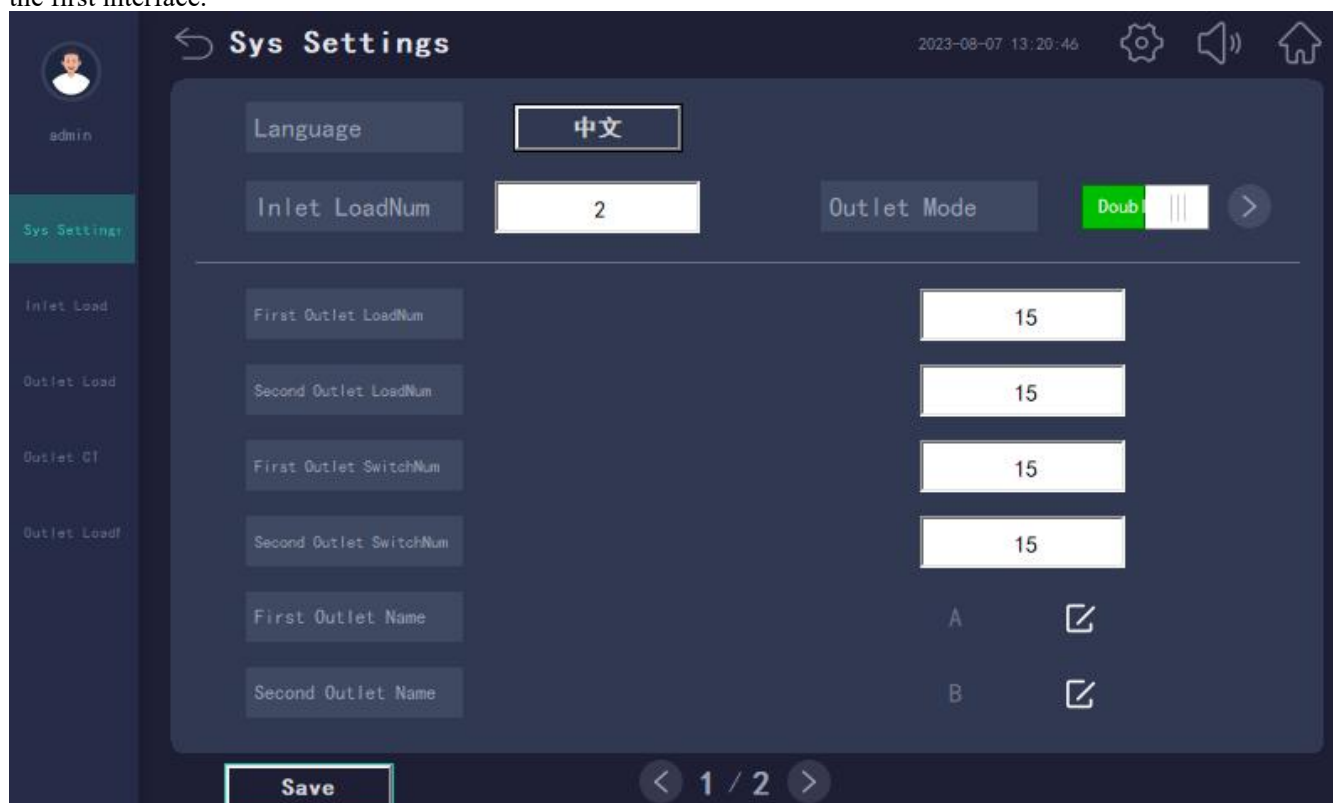

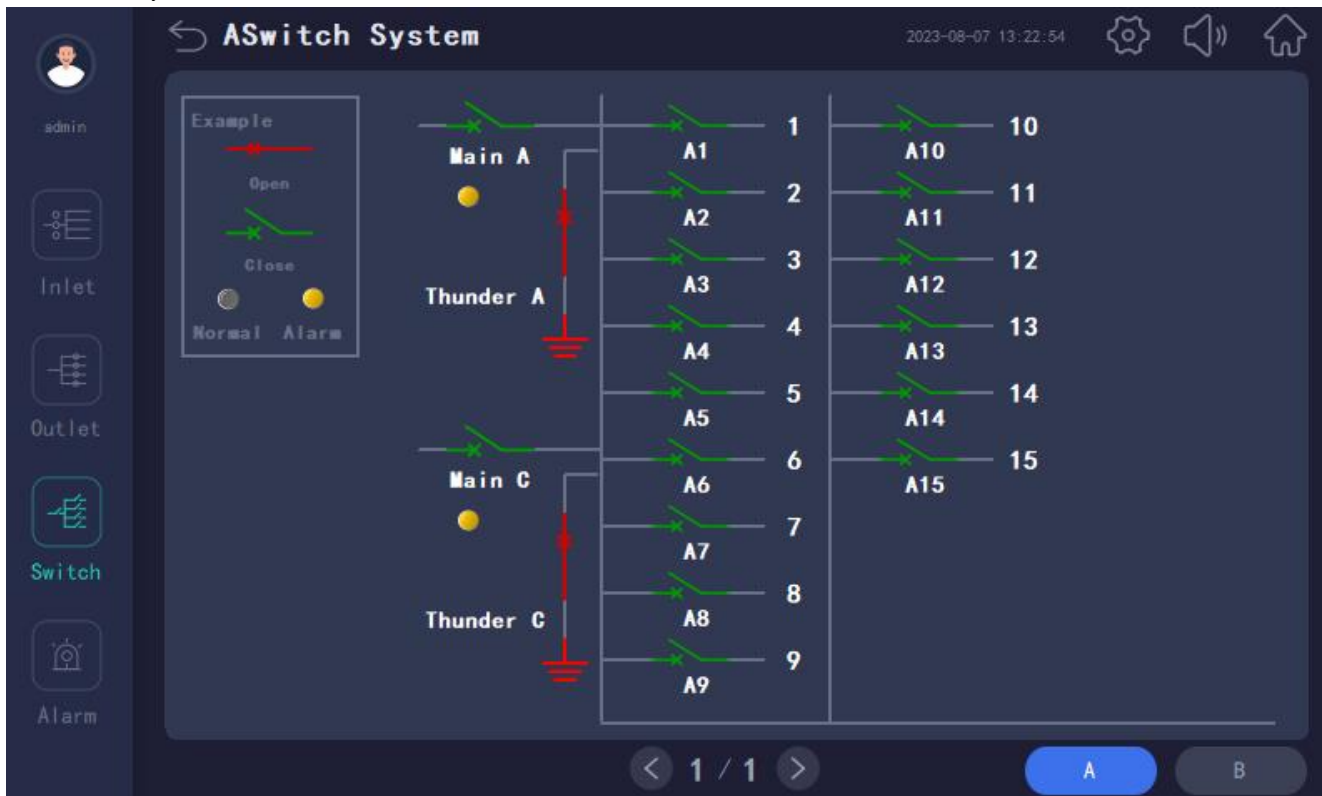

Determine how many incoming and outgoing lines there are based on the system drawings. It should be noted that if the system is not a one in one out or two in two out system, refer to the display pattern described in the parameter display section and switch status interface above.

The detailed configuration of the outgoing mode requires entering a password and is not open. When the wiring is special, please contact our company to change the settings here.

Modify the number of circuits and switch circuits according to the drawing and actual application. The range of the number of outgoing line 1 circuits is 0~192, the range of the number of outgoing line 2 circuits is 0~100, the range of the number of outgoing line 1 switches is 0~192, and the range of the number of outgoing line 2 switches is 0~100.

Virtual summary function: This function can be enabled on page 2 of the system circuit settings. If necessary, after opening it, you can enter the configuration interface to select and group each circuit. Click on the "Virtual Summary Table" in the outlet parameter interface to view the current, power, and energy data of each group. The data of each group is the total data of the circuits set into that group.

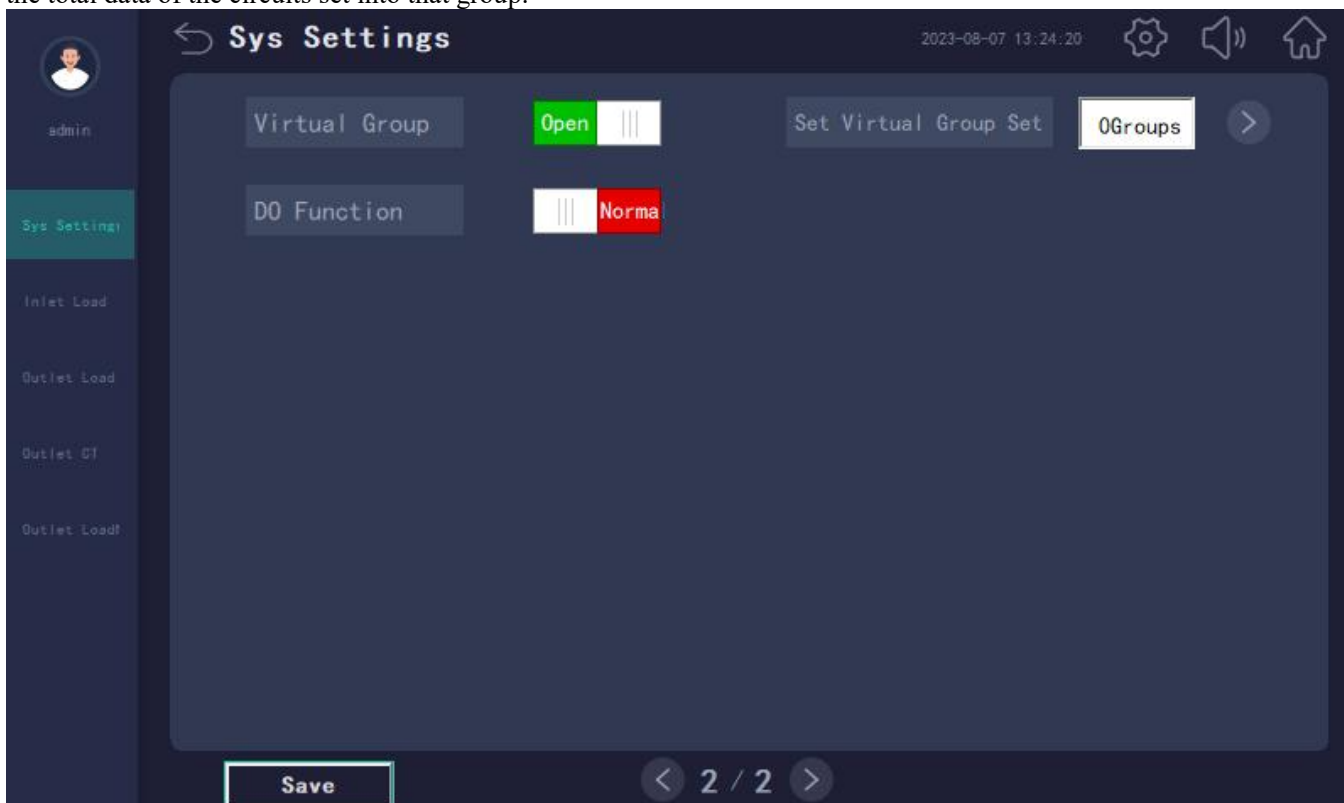

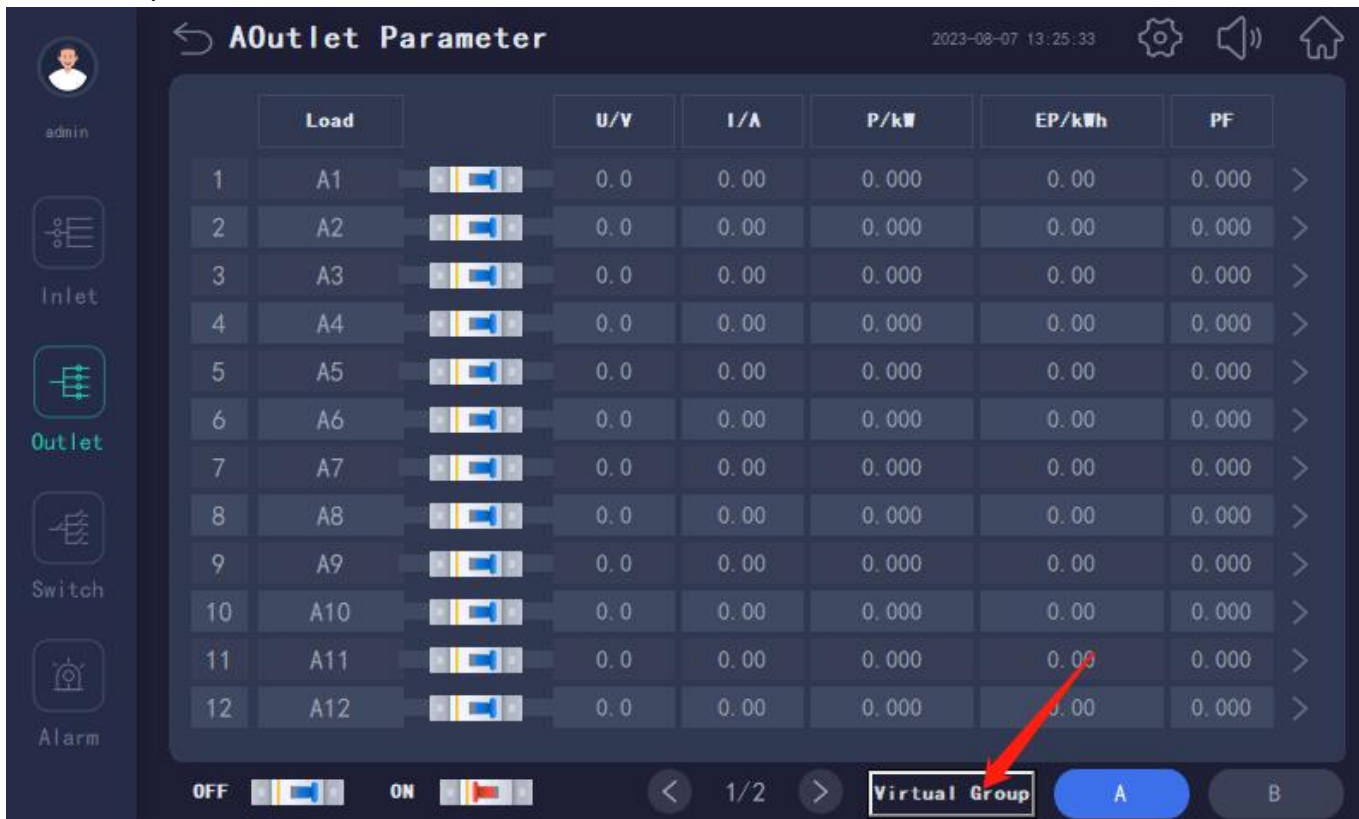

DO Configuration: If two incoming and outgoing lines need to use DO for Alarm output, enter the second page of the system circuit settings to set the DO configuration to two channels.

7.7.2 Line load related

Click the switch button "Incoming line load related" left to modify the incoming line switch load rated value and incoming line CT ratio.

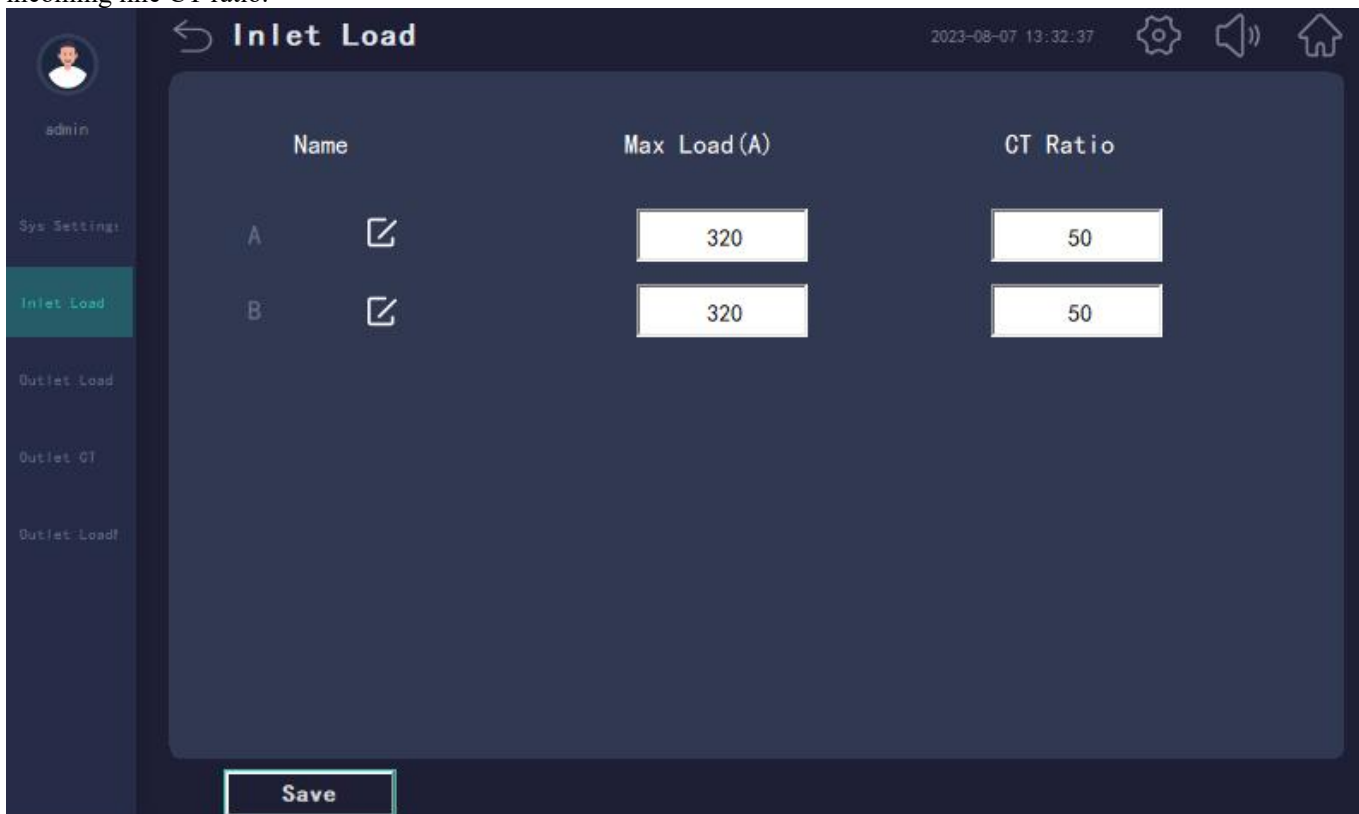

The load rating of the incoming switch is the indicated load current of the switch actually used. It is used to automatically calculate the overload limit value of incoming line load. Please refer to the alarm settings below to modify the load rating here. The default overload limit for the first section is 60% of the rated value here, and for the second section, it is 80%.

The incoming line CT transformation ratio is obtained according to the incoming line transformer used, which is the ratio of the transformer value, for example: if the transformer model is 100A/5A, then the CT is set to 20.

7.7.3 Outgoing switch rating

Click the toggle button "Outgoing Switch Rating" below to modify the load rating of the outgoing switch.



The load rating of the outlet switch is the indicated load current of the switch actually used.

Set to automatically calculate the line overload limit value.

It can be set for a single channel, or you can specify a segment of the loop number to set, or you can set all of them to the specified value with one key.

7.7.4 Outgoing current transformation ratio

Click the switch button "Outgoing Current Transformation Ratio" left to modify the outgoing CT transformation ratio.



The load rating of the outgoing line switch is obtained according to the outgoing line transformer used, which is the primary value of the transformer/5. For example: if the transformer model is 100A/50mA, then the CT is set to 20, that is 100/5.

7.7.5 Outlet name

The circuit name can be personalized set to meet the needs of various application scenarios.
Click the switch button "Outgoing Line Name" left to modify the load name of the outgoing circuit.



Click directly on the circuit box to modify the circuit name. Click on the load name modification interface to synchronize the name to the load name and switch name.

The switch name and load name are set independently. Click "Switch Name" on the current interface to enter and modify the switch name.



Click directly on the circuit box to modify the switch name. Click "Name Synchronization" to synchronize the load name to the switch name.

After inserting the U disk behind the touch screen, click "Export name" on the name modification interface, and an EXCEL form will be generated in the U disk. You can use the computer to edit the name of each circuit. After the modification is completed, insert the U disk behind the touch screen and click "Import Name" has been modified. If there are multiple touch screens and the application scenario is the same system, if you want to configure the same circuit name, you can use the same EXCEL file to import multiple touch screens.

The modified load name can be displayed as the modified name for each circuit on the outgoing line parameter interface. And when a relevant alarm is generated, the alarm information is also the corresponding modified name.

Modifying the switch name can display the modified name for each switch circuit on the switch status interface. And when a relevant alarm is generated, the alarm information is also the corresponding modified name.

7.8 Alarm settings

Click "Alarm Settings" on the home page to enter into the settings.

This interface can modify all alarm-related settings.

Any changes to this section must be done by clicking the "Save Settings" button.

7.8.1 Incoming line alarm setting



The "alarm switch" column is used to set whether the alarm is put into use, and unnecessary or unselected alarms can be turned off to prevent false alarms.

Click the page turning button to view other incoming line alarm settings.

7.8.1.1 Phase loss alarm: When the incoming line voltage is lower than the set alarm value, a phase loss alarm will be generated.

7.8.1.2 Under-voltage alarm: When the incoming line voltage is lower than the set alarm value and higher than the alarm value set for phase loss alarm, an under-voltage alarm will be generated.

7.8.1.3 Over-voltage alarm: When the incoming line voltage is higher than the set alarm value, an over-voltage alarm will be generated.

7.8.1.4 First-Stage undercurrent alarm: When the incoming line current is lower than the set alarm value, an undercurrent alarm will be generated.

7.8.1.5 Second-stage undercurrent alarm: When the incoming line current is lower than the set alarm value, a second-stage undercurrent alarm will be generated.

7.8.1.6 First-stage over-current alarm: When the incoming line current is higher than the set alarm value, a one-stage over-current alarm will be generated.

7.8.1.7 Second-stage over-current alarm: When the incoming line current is higher than the set alarm value, a second-stage over-current alarm will be generated.

7.8.1.8 Power over-limit alarm: When the incoming line power is higher than the set alarm value, a power over-limit alarm will be generated.

7.8.1.9 Under-frequency alarm: When the frequency is lower than the set alarm value, an under-frequency alarm will be generated.

7.8.1.10 Over-frequency alarm: When the frequency is higher than the set alarm value, an over-frequency alarm will be generated.

7.8.1.11 Voltage three-phase unbalance alarm: When the three-phase unbalance of incoming line voltage is higher than the set alarm value, a voltage three-phase unbalance alarm will be generated.

7.8.1.12 Current three-phase unbalanced alarm: When the incoming line current three-phase unevenness is higher than the set alarm value, a current three-phase unbalanced alarm will be generated.

7.8.1.13 Zero-ground voltage alarm: When the neutral-ground voltage is higher than the set alarm value, a zero-ground voltage alarm will be generated.

7.8.1.14 Zero-sequence current alarm: When the zero-sequence current is higher than the set alarm value, a zero-sequence current alarm will be generated.

7.8.1.15 Leakage current alarm: When the leakage current is higher than the set alarm value, a leakage current alarm will be generated. If the leakage current is not measured, that is, there is no leakage current transformer and related wiring, the value of the leakage current is 0 by default. At this time, it is lower than the set alarm value, and the alarm switch can not be turned off and no false alarm will be generated. The same is as below.

7.8.1.16 Cabinet temperature alarm: When the cabinet temperature is higher than the set alarm value, an over-temperature alarm will be generated.

7.8.1.17 Cabinet humidity alarm: When the humidity of the cabinet is higher than the set alarm value, a humidity alarm will be generated.

7.8.1.18 Incoming line passive switch alarm:

The alarm of the passive switch can customize the name, purpose, alarm logic, and whether it is put into use. The following is the initial default usage.



Main circuit switch status: If you select "Passive" in the "Collection Mode" column, you can directly collect the auxiliary contact switch signal, DI points taken from the AMC100-ZA module, and if you choose "Active", you can directly collect the voltage to judge. If you select "Normally Open" in the "Wiring Type" column, the AMC acquisition module terminal detection status is green when it is closed, and red when it is disconnected, and the main circuit switch alarm will be generated from closed to open. If you select "Normally Closed", the terminal detection status of the module is closed. It is red, and it is green when it is disconnected, and the main circuit switch alarm will be generated from disconnection to closure. If this function is not used, you can select "Hide" in the "Display" column to cancel the display of the switch on the switch status interface. If you only need to display no alarm, you can select "Close" in the "Alarm Switch", and the main switch will only display no alarm.

Main circuit trip status: If “Normal Closed” is selected in the “Connection Type” column, the terminal detection status of the AMC acquisition module will generate main circuit trip alarm from close to open. If “Normally Open” is selected, the module terminal detection status will generate a main circuit trip alarm from open to close. If this function is not used, you can select “Hide” in the “Display” column to cancel the display of the switch in the switch status interface. If you only need to display and do not need an alarm, you can select “off” in the “alarm switch” to display only the main circuit trip without an alarm.

Main road lightning protection switch: select “Normally Closed” in the “Connection Type” column, the AMC acquisition module terminal detection status will be green when it is closed, and red when it is disconnected, and the main road lightning protection alarm will be generated from closed to disconnection. Then the module terminal detection status is red when it is closed, and green when it is disconnected, and the main road lightning protection alarm will be generated from disconnection to closure. If this function is not used, you can select "Hide" in the "Display" column to cancel the display of the switch on the switch status interface. If you only need to display and do not need to alarm, you can select "Close" in the "Alarm Switch", and the main road lightning protection will only display and not alarm.

Reserved switch acquisition: If “Normally Closed” is selected in the “Wiring Type” column, the AMC acquisition module terminal detection status will be closed in green and open in red, and an alarm will be closed in green and open in red, and an alarm will be generated from close to open. If “Normally Open” is selected, the module terminal detection status will be closed in red and open in green, and an alarm will be generated from open to close.

It should be noted that all four switch legends are fixed. In the theory, one AMC100-ZA has a total of 8 DI input points that can measure any switch input, not limited to the main circuit switch status, tripping, and lighting protection. The name can be modified to match the actual tested switch value, but the display style of the switch is fixed. If the tripping point type and lighting protection grounding style do not match the current detected switch, the reserved switch can be opened, the style is consistent with the main circuit switch, and the detection position on the module is at the 4th DI point.

7.8.2 Outgoing Line alarm setting

Click the switch button "Outgoing Line Alarm Setting" below to set the relevant alarm for the outgoing line.

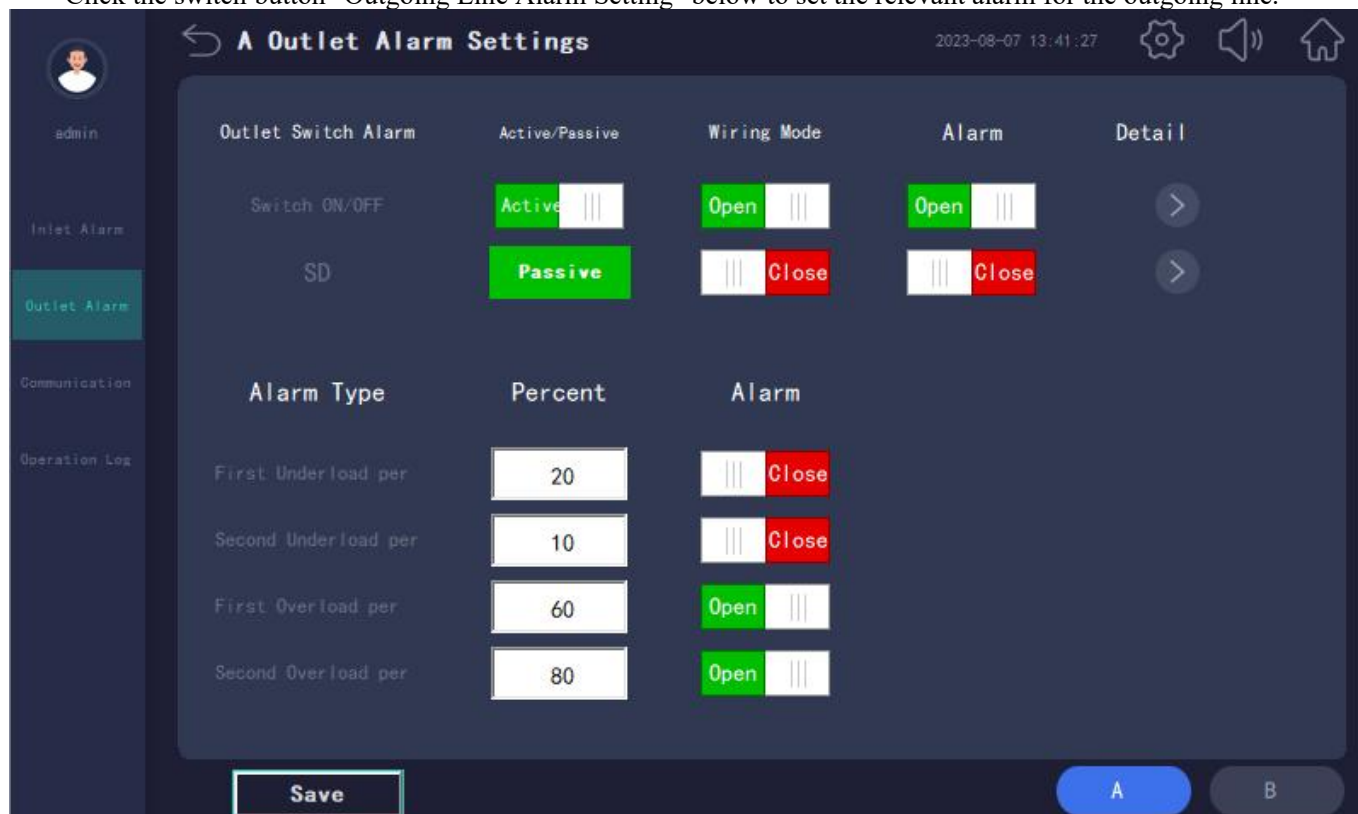

7.8.2.1 Outgoing Line switch alarm:

Switch opening alarm: Select "Active" in the "Acquisition Mode" column to directly collect the voltage to judge. If you select "Passive", use the KD module to collect passive switch signals. Select "Normally Open" in the "Wiring Type" column, and the switch status detected on the module terminal is green for closing and red for opening, and an alarm for switch opening will be generated from closing to opening. The module terminal detection status is red when it is closed, and green when it is disconnected, and a switch opening alarm will be generated from disconnection to closure. If no alarm is required, select “Off” in the “Alarm Switch” column. You can click the arrow in the "Individual Settings" column to set whether the alarm of each channel is enabled or not. The default switch alarm start and stop is based on the number of switch circuits currently set, The switch alarms within the range of the number of channels are all turned on, and the switch alarms exceeding the number of channels are all turned off.



7.8.2.2 Switch failure alarm: If the system requires SD alarm, enable the alarm in the "Alarm Switch" column. Select "Normally Closed" in the "Wiring Type" column, and the detection status of the KD module terminal is green when it is closed, and red when it is disconnected, and the main circuit trip alarm will be generated when it is closed to disconnected. If you select "Normally Open", the detection status of the KD module terminal is Red, open to green, and from open to closed will generate a switch trip alarm.

7.8.2.3 Undercurrent alarm for one section of outgoing line: When the current value of a certain circuit is lower than the product of the switch rating of this circuit and the value set for the undercurrent percentage of one section, an undercurrent alarm for one section of this circuit will be generated.

7.8.2.4 Second-stage undercurrent alarm of outgoing line: When the current value of a certain circuit is lower than the product of the switch rated value of this circuit and the value set by the second-stage undercurrent percentage, the second-stage undercurrent alarm of this circuit will be generated.

7.8.2.5 One-stage over-current alarm of outgoing line: When the current value of a certain circuit is higher than the product of the switch rated value of the circuit and the value set by the one-stage over-current percentage, an over-current alarm of the one-stage section of the circuit will be generated.

7.8.2.6 Second-stage over-current alarm of outgoing line: When the current value of a certain circuit is higher than the product of the switch rated value of this circuit and the value set by the second-stage over-current percentage, the second-stage over-current alarm of this circuit will be generated.

7.8.3 Communication alarm

After the module and touch screen wiring are completed, the initial debugging needs to enter this interface. fill in the actual slave module address from small to large, usually the address label affixed to the module. The default regulations are as follows:

- AMC100-FAK48 10~19
- AMC100-FAK30 20~29
- AMC100-FDK48 10~19
- AMC100-FDK30 20~29
- AMC100-FT48 30~39
- AMC100-FT30 40~49
- AMC100-KD48 50~59
- AMC100-KD30 60~69
- AMC100-KA48 70~79
- AMC100-KA30 80~89

Example: If one AMC100-FAK48 and one AMC100-FAK30 slave modules are used, then slave address 1 is set to 10 and slave address 2 is set to 20.

After completing the above equipment, click Return. If a module communication alarm is generated, first observe what module's alarm is, and then go to the Communication Alarm interface to check the address.



If the alarm message is "communication failure of incoming line module", check the address of the main module on this interface. The address of the main module should be 1. It is necessary to check whether the address of the main module actually used is 1. If it does not match, it needs to be changed to 1.

Click the "Read Address" button on the right side of the word "Main Module Address", and observe whether the address read in the display box is 1. If it is 0 and there is no change, you need to check the wiring. If it is not 1, you need to write the address. Enter 1 on the right side of the button and click "Write Address", then click "Read Address" to check whether the address is successfully changed to 1.

If there are words such as slave communication failure in the alarm message, it is necessary to modify the address of the slave module. If there are multiple slave communication faults, each slave module needs to modify its address separately. For example, if the slave machine uses one AMC100-FAK48, and according to the address regulations, the address of this AMC100-FAK48 should be 10 (which should be 10 instead of the actual module address being 10, that is the actual module address needs to be changed to 10), then ensure that target slave module is separately connected to the main module. If there are other slave modules, they must be disconnected and unplugged from the communication cable.

Change the position with the serial number 1 below the slave address to 0.



Write 10 in the input box to the right of the Write Address button in the slave address area, and then click Write Address. Click the read address button in the slave address area, and the box on the right displays 10, indicating successful modification. After modification, restore the address specified in the above regulations from the machine address settings.

To prevent misoperation from causing normal communication to become abnormal communication, all secondary operation passwords are written and set.

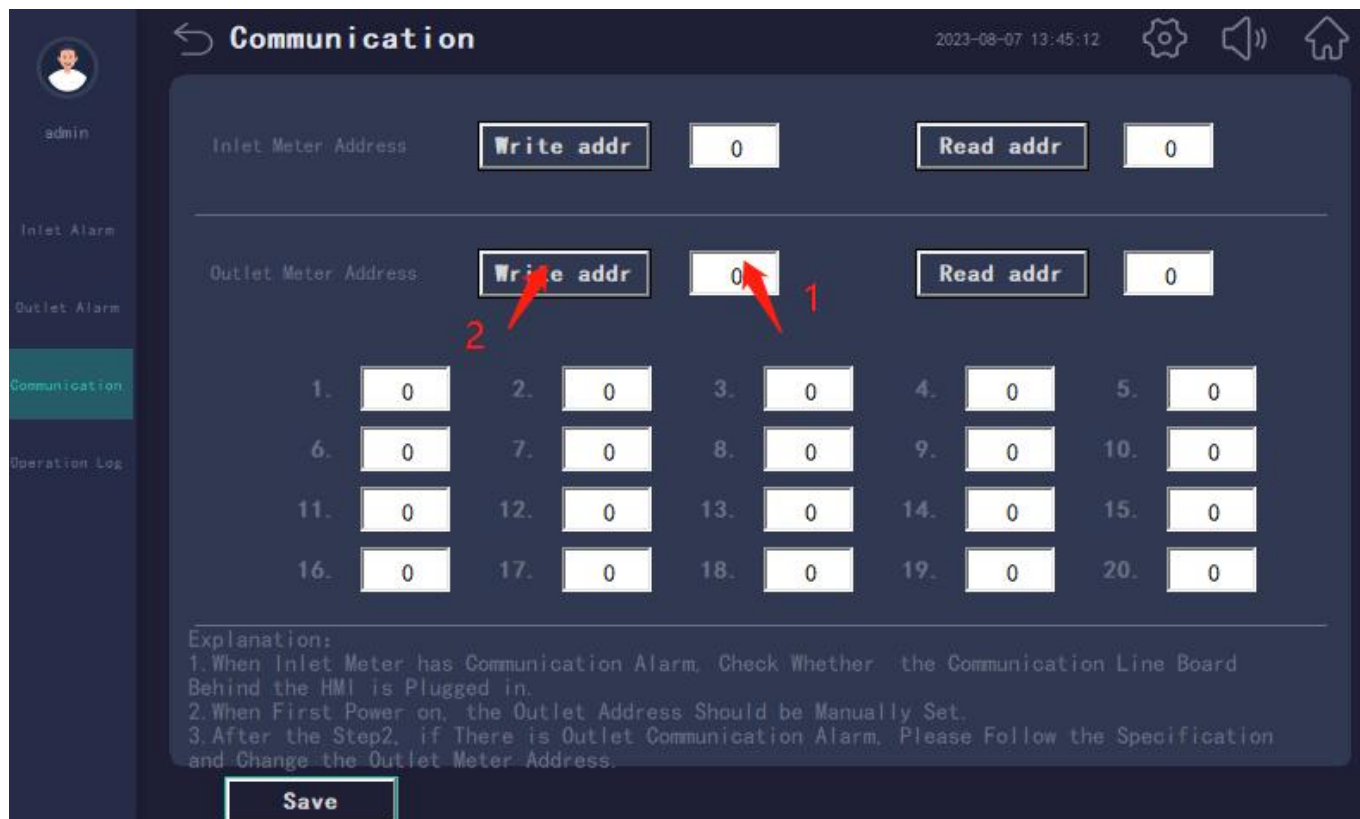

7.9 Data Clearing

Clear energy data generated while in use or during commissioning.



Click "Data Clear" on the home page to enter and delete the corresponding energy data.

If you want to clear the data of a certain loop, fill in the serial number of the corresponding loop in the box, and click the clear button on the right.

All reset operations require a second password to prevent malicious modification.

7.10 Background communication

If the actual application scenario requires background dynamic rings, etc., click on the background communication button on the homepage to enter, you can change the forwarding address on this interface to communicate with the background system.

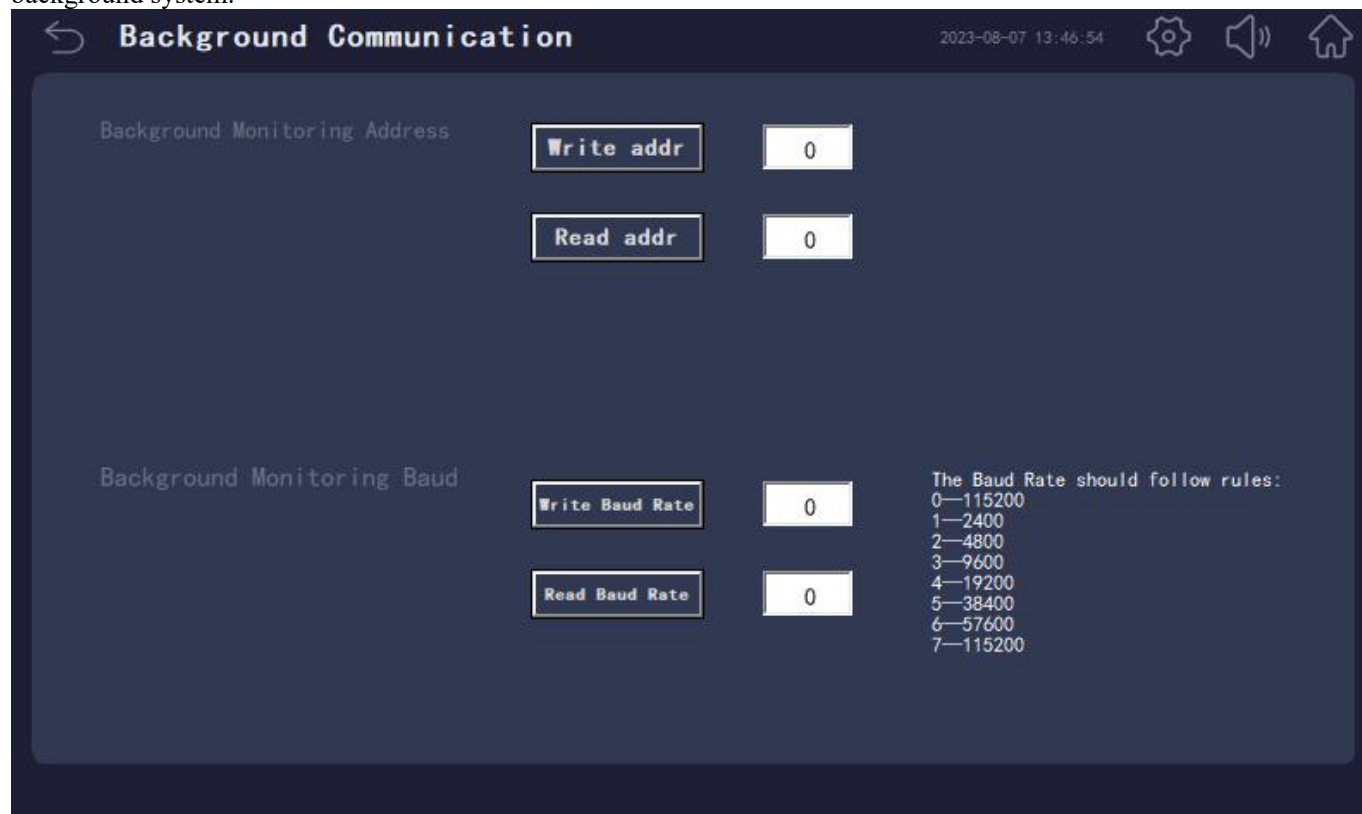

First input in the input box, then click the button in front of the input box to complete the modification.

Marketing Manager: Daisylin li WhatsApp: +8613774416773 Tel: +8613774416773
E-mail: Daisylin@acrel-electric.com Web: acrel-electric.se

Manual Revision Record

Date	Old version	New version	Revision
		V1.0	1.First writing
2022.6.24	V1.0	V1.1	1.Add the overall dimension diagram of the touch screen
2022.10.20	V1.1	V1.2	1.Correcting text errors in the text
2023.8.11	V1.2	V1.3	1.Modify the image and language description of the touch screen interface section

Marketing Manager: Daisylin li WhatsApp: +8613774416773 Tel: +8613774416773
E-mail: Daisylin@acrel-electric.com Web: acrel-electric.se